



PROEL 

VOICE
ALARM
EQUIPMENT

COMMERCIAL AUDIO
2019



PROEL

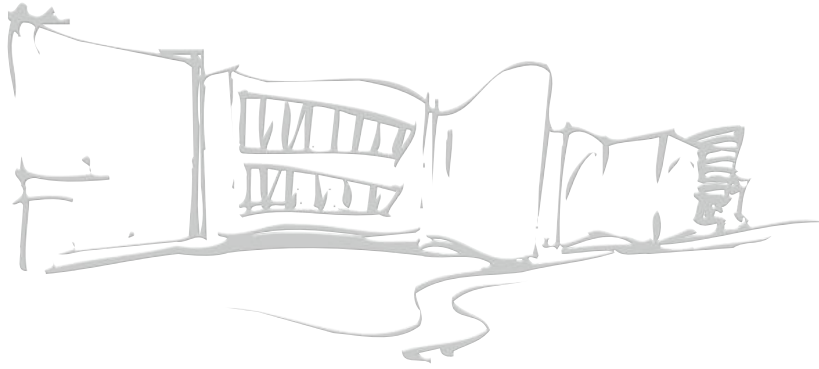

Proel is a leading international company specialized in the **design, production and distribution of audio, video and lighting systems for live entertainment and fixed installations.**

The company was founded in 1991 and has its headquarter in Sant'Omero, Italy.

Proel's ultimate aim is **customer satisfaction**, achieved by the delivery of **top-quality products and top-quality service**, constantly and energetically striving to provide and develop solutions and products that are able to meet many different needs and specifications.



Since its origins, the **Italian spirit** characterises Proel's approach to everything the company does. A company born out from **love for beauty, design, and minute attention to detail**: the reasons why Proel's "**MADE, MADE, MADE IN ITALY**" concept is a guarantee of **quality and high-tech solutions.**

The new EN54 product line is the synthesis of 30 years of Proel's experience in designing, engineering and manufacturing sound reinforcement systems in Italy.

We are proud of the know-how we have achieved but we constantly outlook to increase our knowledge. Our products are manufactured under the strictest factory process control as prescribed by the EN54 certifications.

PROEL INTERNAL STRUCTURE

LISTENING TO THE MARKET



1

R&D

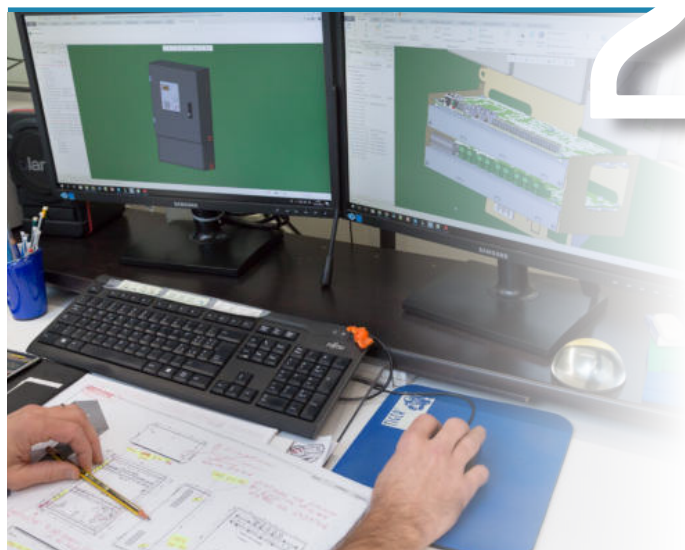

2

PRODUCTION



3

SYSTEM DESIGN



4

OUR MANAGEMENT POLICY



We deliver total quality to make our customers fully confident in our products



We maintain an open communication with our customers throughout the process: product concept, project design, after sales support



When it comes to give the right solution, we first make ourselves the right question



We design and manufacture all our products applying all laws and regulations in force

OUR STRENGTHS



Highly skilled personnel



Design of dedicated systems and solutions



Support during installation and commissioning



Comprehensive technical documentation



High competitiveness

WHERE WE ARE HEARD



HOSPITAL



SPORT FACILITIES



INDUSTRY



HOTELS



**TRANSPORT/
LOGISTIC**



RETAIL



PUBLIC BUILDING

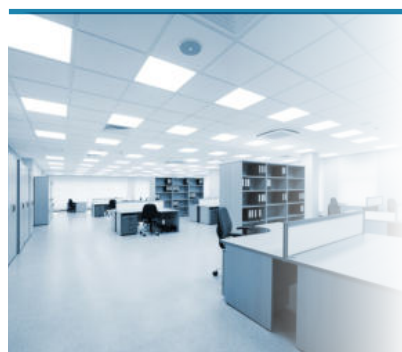

OFFICE COMPLEXES

VOICE ALARM EQUIPMENT

This new product line is Proel's response to the increasing demand for EN54 certified audio systems for both fire alarm and general announcement purposes, from simple stand-alone setups, up to extended multi-zone installations. With the new EVAC product line, Proel's Commercial Audio division becomes the key player in the world of certified fire alarm audio systems. With our R&D department and our capillary sales and after sales network, we create and provide a complete range of solutions to satisfy any requirement.

A continuous listening to the market needs, combined with a focused research and development team taking advantage of cutting edge technologies, allows us to always design one step ahead products, thus keeping their installation as simple as their daily use.

VAE MODULAR SYSTEM

VAE COMPACT ALL-IN-ONE

EMERGENCY AND ANNOUNCEMENT CALL STATIONS

ARTIA SERIES





VAE MODULAR SYSTEMS EN54-16 EN54-4 CERTIFIED

No matter how huge or tiny your building is. No matter how many zones and how much power you need. No matter how many messages you have to send or how many call stations you should fit. VAE modular emergency voice alarm and general announcement sound system is always tailored to your facility, combining flexibility, performance and cost efficiency.

How we did this? Each item and module of the system is like a primary color on the artist's palette. Joining them we can offer you infinite unique masterpieces.

VAE MODULAR SYSTEM

PA AEM5Z

The PA AEM5Z is the modular system main controller that features all functions prescribed by the EN 60849, EN 54-16 and BS 5839-8 standards. Not just a unit to perform itself monitoring and signal path integrity, but an advanced system manager that routes emergency calls, general announcements and recorded messages. Its intuitive programming software allows you to configure the simplest setup, up to the widest multi-zone system. Thanks to its multiple message players, you can forward simultaneously up to 108 different recorded messages on 108 zones, or if needed, one at the time. In any case, one dedicated alarm message for each zone.



FEATURES

- EN 54-16 certified
- Up to 5 direct plug-in modules for the amplifier/line management
- Up to 108 zones
- LCD Display with navigation buttons
- LEDs: Power, Fault Warning and Voice Alarm
- Front USB port for configuration download
- 24V dc power supply input
- Spare amplifier input
- Two RJ45 connectors to the Slave units
- Two RJ45 busses microphone stations connections (up to 108 microphone units)
- Two monitored alarm message input triggers
- Common fault out
- 2 rack unit 19" Standard

PA AES8Z

The 5 zones handled by the PA AEM5Z are not enough? You can daisy chain many PA AES8Z slave units and fill them with their line controllers to manage a building as big as 108 zones are.



FEATURES

- EN 54-16 certified
- Up to 8 direct plug-in modules for the amplifier/line management
- LEDs: Power, Fault Warning e Voice Alarm
- 24 V dc power supply input
- Spare amplifier input
- Two RJ45 connectors to from and to Master or Slave units
- 2 rack unit 19" Standard

PA EV MCL1Z

The 5 zones handled by the PA AEM5Z are not enough? You can daisy chain as many PA AES8Z slave units and fill them with their line controllers to manage a building as big as 108 zones are.



FEATURES

- Direct connection to the power amplifier
- Output connector 100V line

PA EV MCL2Z

Zone controller managing the loudspeaker line and performing continuous monitoring. The module fits into the AEM5Z Master matrix or AES8Z Slave matrix. Operates together with the EV MCL1Z A-Line module in setups where high-power redundant A+B loudspeaker lines are needed.



FEATURES

- Connector for connecting the amplifier output
- Output connector 100V line

PA AELAB

Zone controller managing the amplifier and the redundant loudspeaker lines (A+B) performing continuous monitoring. The module fits into the AEM5Z Master matrix or AES8Z Slave matrix.



FEATURES

- 24bit 48Khz DSP based audio management
- Direct connections to the power amplifier
- Output connector for redundant loudspeaker lines (A+B)
- Monitored inputs for the activation of two locally stored customizable messages
- BGM input, selectable hardware

VAE MODULAR SYSTEM

PA DM250/550/750

Digital Modular Power Amplifier Series

The design of new 100V DMPower amplifier series was targeted to fulfil the most demanding needs of a market in a continuous evolution: they respond to the most strict operating criteria and they are built to ensure absolute reliability in 24/7 operation. They are not only the ideal companion of VAE Modular Voice Alarm System, but can also live as a stand-alone setup to manage background music and general announcements from a microphone station. Thanks to the most efficient SMPS power supply and transformerless power stage, we have created the most compact, powerful and fully featured dual supply Public Address amplifier. Get one and you won't get any other.



KEY POINT

Modular, Compact, Powerful

Three power versions: 250W from the DMP250, 550W from the DMP550 and 750W from the DMP750. Up to 8 channels and 6.000W of audio power in a single 3U Rack frame.

Fully Featured, Totally Versatile

AC Mains and 48Vdc dual input power. Line and microphone inputs with priority selection or Soft-Vox.

DSP-Onboard

All DMPower amplifiers come with PA-Taylorred algorithms such as tone controls and dynamics and load management.

Smart User Interface

Straightforward commands and indicators with potentiometer position recall.

Multi-Level Protection and Self Fault Recovery

Microprocessor advanced monitoring and system management will always keep the amp and your loudspeakers safe.

A+++ Energy Efficiency

DMPower amplifiers are GREEN! Very low quiescent current and "No-Signal Auto Shutdown" mean energy saving: low power consumption and small back-up battery size.

PA MDAC8

8 units rack mount frame (3U rack 19") for DMPower series



TECHNICAL SPECIFICATIONS

Model series DMPower	DM750	DM550	DM250
Constant voltage speaker output	100V - 70V selectable	100V - 70V selectable	100V - 70V selectable
Max Output power RMS @100V	750W	550W	250W
Peak output current	9.40A	6.90A	3.20A
Minimum Load Impedance	13.3 Ohm	18.2 Ohm	40 Ohm
Frequency response	50Hz ÷ 20KHz ±3db 440Hz ÷ 20KHz ±3db (selectable)	50Hz ÷ 20KHz ±3db 440Hz ÷ 20KHz ±3db (selectable)	50Hz ÷ 20KHz ±3db 440Hz ÷ 20KHz ±3db (selectable)
S/N Ratio	> 110 dbA (20Hz ÷ 20KHz)	> 110 dbA (20Hz ÷ 20KHz)	> 110 dbA (20Hz ÷ 20KHz)
Distortion (THD+N)	< 0.05 dbu (1W ÷ Max Power)	< 0.05 dbu (1W ÷ Max Power)	< 0.05 dbu (1W ÷ Max Power)
Input Impedance	10KΩ	10KΩ	10KΩ
Input Sensitivity (mV)	100÷1000 (Priority Input) 550 (Line Input)	100÷1000 (Priority Input) 550 (Line Input)	100÷1000 (Priority Input) 550 (Line Input)
Maximum Input Voltage (V)	5.50 Vp-p / +8.0 dBu	5.50 Vp-p / +8.0 dBu	5.50 Vp-p / +8.0 dBu
DSP audio processing	24bit 48Khz, Volume control, Mic Gain control, Soft-VOX, Tone controls	24bit 48Khz, Volume control, Mic Gain control, Soft-VOX, Tone controls	24bit 48Khz, Volume control, Mic Gain control, Soft-VOX, Tone controls
Ac Power Supply			
Input Voltage (V~)	230VAc (+10% / -15%)	230VAc (+10% / -15%)	230VAc (+10% / -15%)
Input Frequency (Hz)	50 / 60 ± 10%	50 / 60 ± 10%	50 / 60 ± 10%
Max Average Input Current	2.6A (pink noise, max load)	1.9A (pink noise, max load)	0.95A (pink noise, max load)
Dc Power Supply			
Input Voltage (Vdc) 48V.DC nominal	42 ÷ 55 Vdc	42 ÷ 55 Vdc	42 ÷ 55 Vdc
No-Signal current consumption	50mA	50mA	50mA
Max Average Input Current	13A (pink noise, max load)	9.5A (pink noise, max load)	4.5A (pink noise, max load)
Input/Output Connectors			
Primary power supply (V~)	IEC panel connector	IEC panel connector	IEC panel connector
Auxiliary power supply (V.-/+ dc)	Polarized panel connector	Polarized panel connector	Polarized panel connector
Speaker Output	Terminal block (Euroblock)	Terminal block (Euroblock)	Terminal block (Euroblock)
Signal Input	Terminal block (Euroblock)	Terminal block (Euroblock)	Terminal block (Euroblock)
MIC Input	Polarized panel connector/RJ45	Polarized panel connector/RJ45	Polarized panel connector/RJ45
Std-By	Terminal block (Euroblock)	Terminal block (Euroblock)	Terminal block (Euroblock)
Controls & Indicators			
Indicators	ON/Std-By, Signal/Clip/Limit, Protect/Temp	ON/Std-By, Signal/Clip/Limit, Protect/Temp	ON/Std-By, Signal/Clip/Limit, Protect/Temp
Controls	Master Volume, Treble, Bass, 440Hz Cut, Mic Gain, Vox Gain, Std-By	Master Volume, Treble, Bass, 440Hz Cut, Mic Gain, Vox Gain, Std-By	Master Volume, Treble, Bass, 440Hz Cut, Mic Gain, Vox Gain, Std-By
Protection			
Speaker overload protection	Microprocessor based, current limiter	Microprocessor based, current limiter	Microprocessor based, current limiter
Speaker short-circuit protection	Microprocessor based	Microprocessor based	Microprocessor based
Thermal management	Microprocessor based:Fan Speed, signal attenuation, shutdown	Microprocessor based: Fan Speed, signal attenuation, shutdown	Microprocessor based: Fan Speed, signal attenuation, shutdown
DC power protection	Fuse, polarity inversion	Fuse, polarity inversion	Fuse, polarity inversion
Mains power protection	Fuse	Fuse	Fuse
Mains power Spike protection	480 Joules, 2ms	480 Joules, 2ms	480 Joules, 2ms
Clipping protection	DSP based amplitude limiter	DSP based amplitude limiter	DSP based amplitude limiter
General Data			
Audible Noise (dB@1mt)	< 40	< 40	< 40
Operating temperature (°C)	-5 ÷ 40	-5 ÷ 40	-5 ÷ 40
Relative humidity (%)	< 95 (non-condensing)	< 95 (non-condensing)	< 95 (non-condensing)
Dimensions (LxHxP) (mm)	116 x 53 x 367	116 x 53 x 367	116 x 53 x 367
Weight (kg)	2.15	2.15	2.15

VAE MODULAR SYSTEM

TYPICAL 5 ZONES - 10 LINES SYSTEM

FEATURES

- EN 54-16, EN60849 and BS5839-8 compliant
- 5 zones
- Double line for each zone
- 250/550/750W Power for each zone
- Spare amplifier
- One Battery Charge
- 4 pcs. Battery 12V
- One emergency (Fireman) call station (DBEVF)
- One multi zones call station (DBE06)
- One general call station (DBE01)

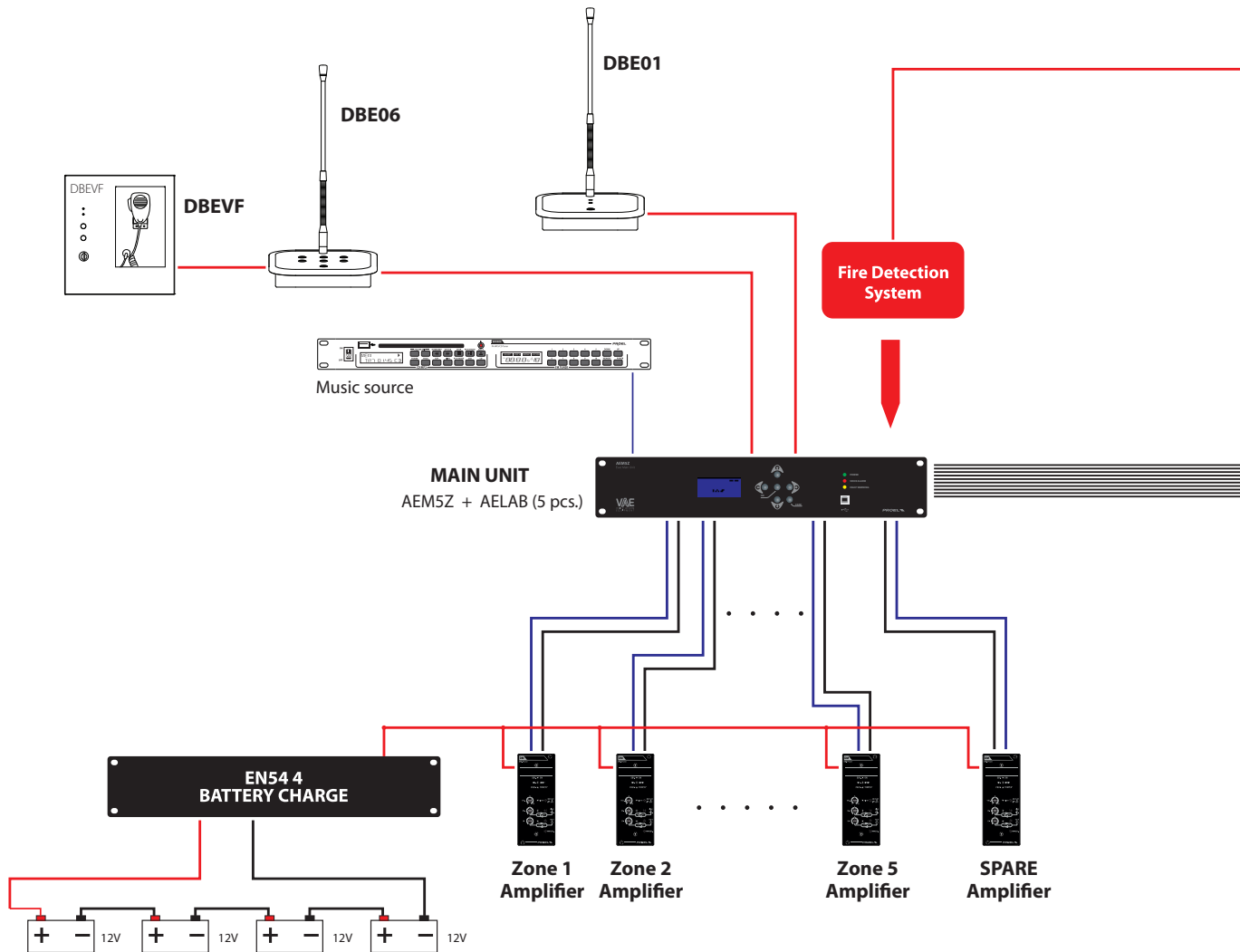
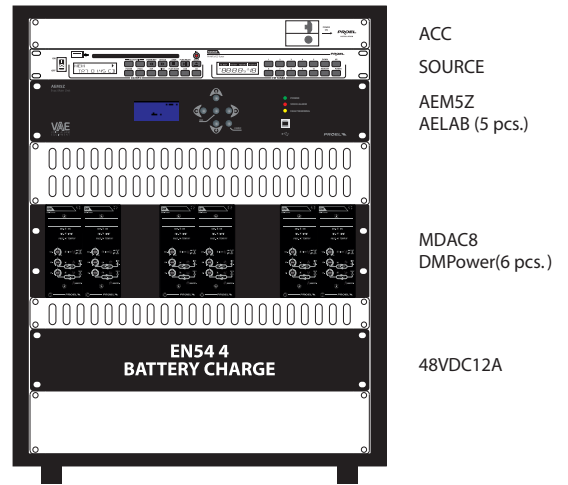

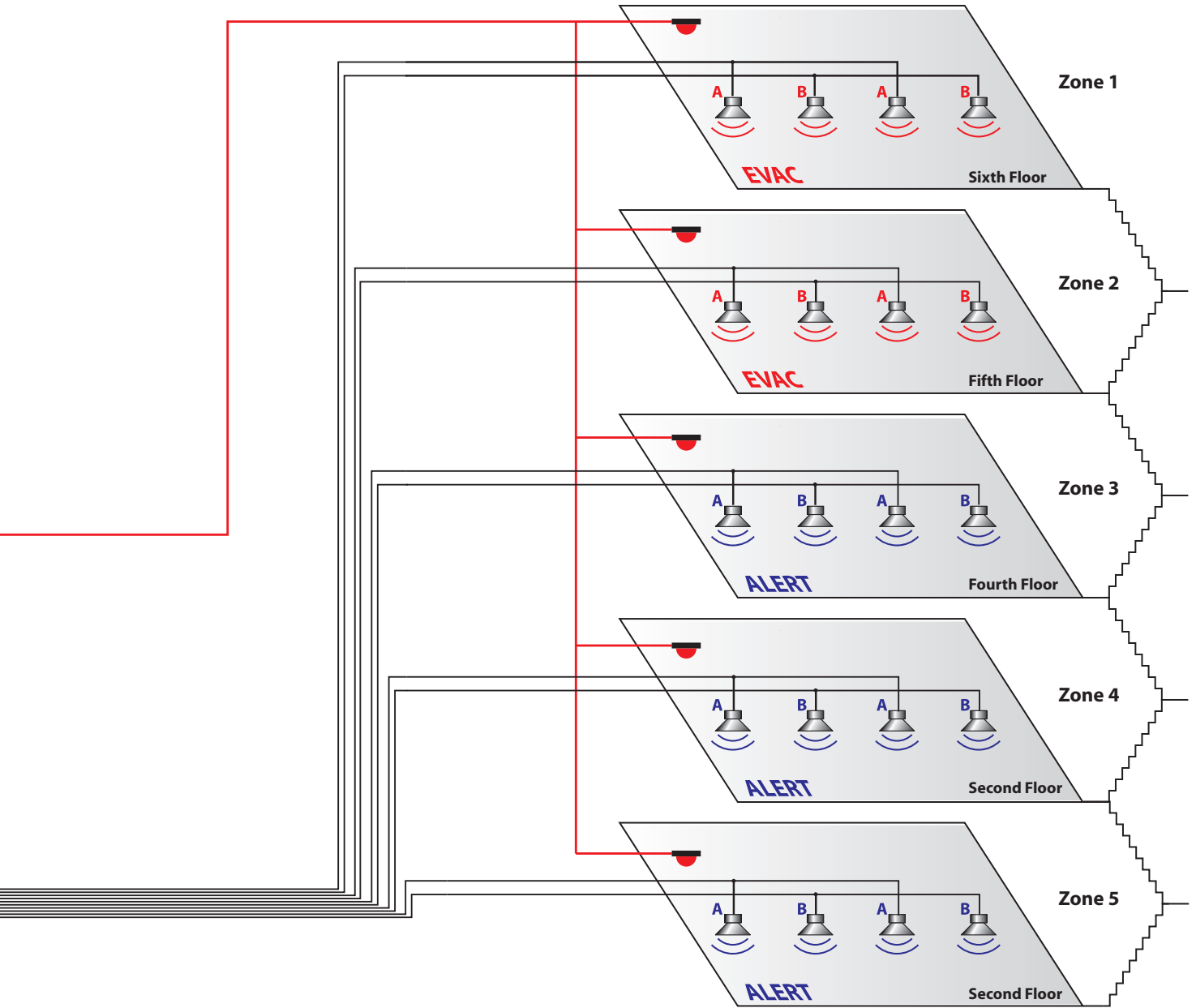

VAE MODULAR SYSTEM

TYPICAL 7 ZONES - 7 LINES SYSTEM

FEATURES

- EN 54-16, EN60849 and BS5839-8 compliant
- 7 zones
- Double line for each zone
- 250/550/750W Power for each zone
- Spare amplifier
- One Battery Charge
- 4 pcs. Battery 12V
- One emergency (Fireman) call station (DBEVF)
- Two multi zones call station (DBE108)

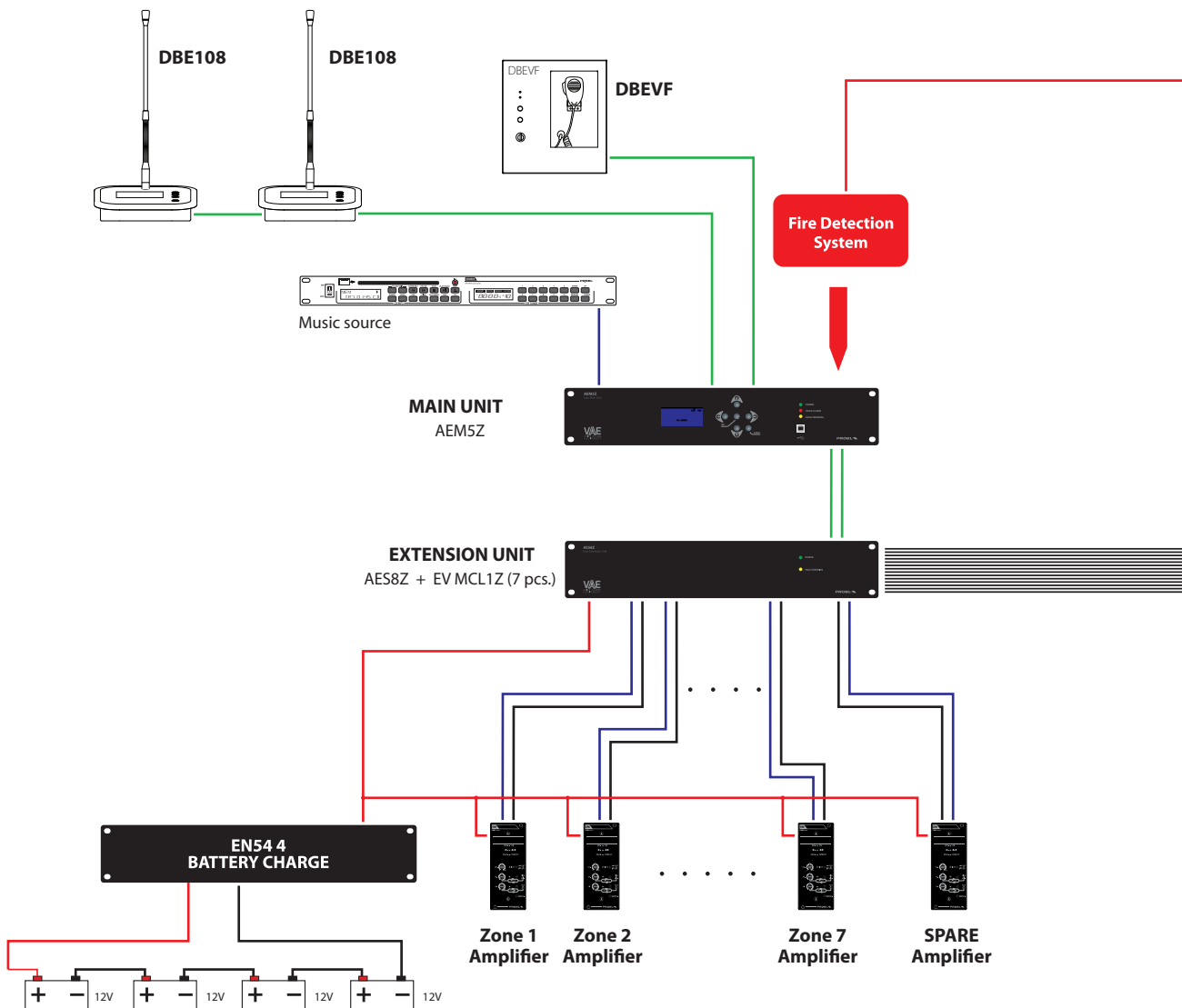
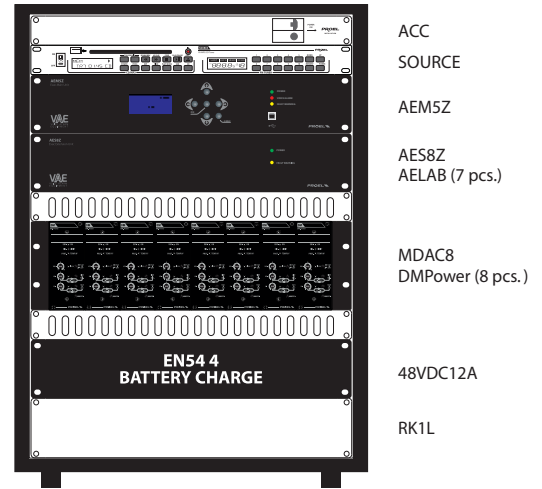

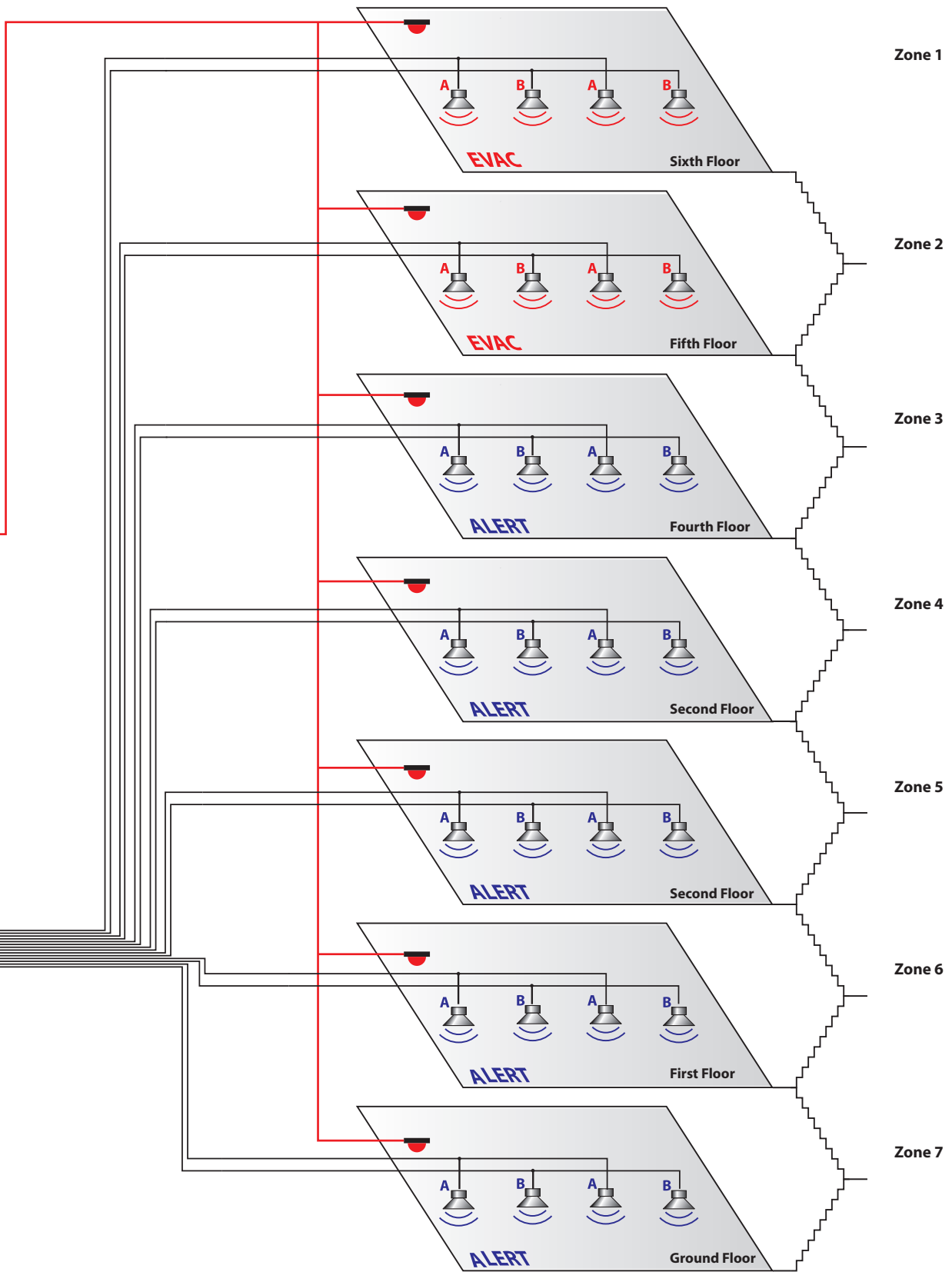

VAE COMPACT, ALL-IN-ONE, EVACUATION SYSTEMS

EN54-16 EN54-4 CERTIFIED

Proel is proud to introduce its range of integrated emergency and general announcement sound systems combining flexibility, ease of use and straightforward installation, confirming our leadership in performance, easy installation and reliability.

THE IDEAL SOLUTION, ALWAYS!

The AE604 and AE300 were engineered according to the same 3 fundamentals:

- Off the shelf, all in one systems
- Straightforward installation
- Ease of use

Following these non renounceable requirements, we have created two complementary products dedicated to different operational environments: the AE300 for small sized buildings, where just a single zone is needed, and the AE604 for medium sized facilities where up to 4 zones are needed.

Finally, in case of more complex installations, both AE300 and AE604 can live together making a scalable, multizone distributed system, thanks to their native networking features.

Now, it's easy to understand why AE300 and AE604 are the ideal solution for schools, halls, supermarkets, hotels, railway stations, hospitals and, in general, all public buildings.

These units both integrate an EN54-16 automatic voice evacuation system and an EN54-4 backup power supply in a monolithic wall-mount steel enclosure. Nothing else is needed: no complex installation, no endless commissioning, no engineering skills. Just take it out of the box, hang it to the wall, make some connections and after a basic self-setup you have your emergency sound system into action.

The systems will trigger recorded evacuation messages from the fire alarm equipment, but also live messages can be radiated through the integrated emergency microphone.

They are not just alarm systems: they feature addressable background music inputs, external microphone inputs for general announcements, external emergency call station inputs, a set of contacts to trigger general recorded messages and finally a user selectable schedule that will allow you to play any recorded announcement at anytime.

Both AE300 and AE604 share a cutting edge DSP architecture and powerful amplifiers to bring clearly bring your emergency alerts from the smallest workshop, up to the widest hall.

INTEGRITY AND CLARITY: ALWAYS!

Proel's integrated evacuation systems are fully supervised according to EN54-16 and EN54-4 standards, to ensure spoken or recorded messages integrity by constantly audio monitoring, power and control paths, from the microphone capsule to the loudspeaker line.

In addition, they implement an advanced amplifier management to grant always a full drive of your loudspeakers, even in case of a failure of one of its integrated power units. Fulfilling the EN54-16 requirements one step ahead.

Our engineers have brought their Audiophile mindset into all of our products, because the quality and intelligibility of your recorded or live alarm message and background music are key features you can't renounce.



PROEL

COMMERCIAL AND INDUSTRIAL
ARTIA
SERIES

VAE COMPACT ALL-IN-ONE

AE604

With AE300 we were pioneers, with AE604 we are innovators.

Wall mounted All-In-One voice alarm system compliant with EN54-16 testing and charge circuit compliant with EN54-4. 4 Zones System on redundant loudspeaker line and backup Amplifier. Main and backup amplifier in class D "Pure Path"[™]. 300W @ 100V on redundant loudspeaker line (A + B). The system does not require a line end resistor.

The system ensures full power performance even with backup power.

Processing circuit by DSP; balanced and isolated background music input, isolated and balanced background music microphone input with selectable 48Vdc phantom power supply and priority activation by contact; monitored input for remote emergency call stations; front panel fitted with monitor loudspeaker, monitored emergency PPT microphone, direct sending message keys, navigation keys, large display with LCD dot matrix. Line output for active sub-woofer; audio messages stored on uSD 16bit 48kHz; 8 general purpose messages with activation from dedicated input, contacts or incorporated scheduler, 8 monitored contacts for emergency announcement activation. 4pcs. 12Vdc batteries 18Ah not included.

FEATURES

- Off the shelf integrated voice alarm system
- Out of the box installation ready
- 4 Zones
- Redundant loudspeaker lines on each zone (A+B)
- High quality full digital audio DSP based architecture
- High output power: 600W
- No end of line required
- Embedded EN54-4 power supply and batteries
- 8 x general purpose triggerable messages
- 2 x voice alarm messages (monitored input triggers)
- 2x Background music input
- Ethernet
- Remove battery case



STAND ALONE APPLICATION

MAXIMUM EXTENSION CAPACITY

- 1 x AE604
- 8 x DBE01 or DBE06 or DBEVF

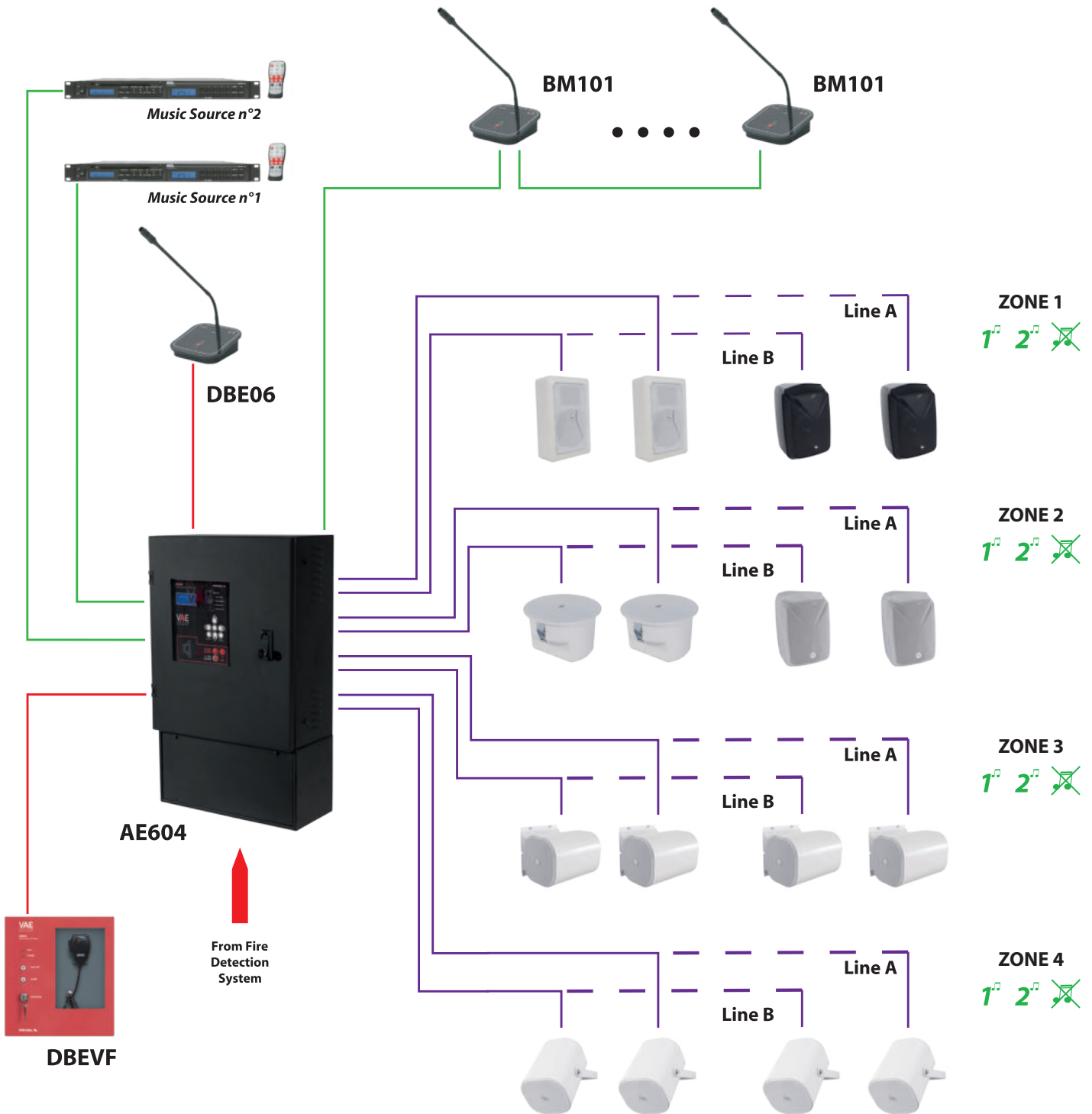

VAE COMPACT ALL-IN-ONE

NETWORK APPLICATION

MAXIMUM EXTENSION CAPACITY

- 8 x AE604/AE300
- 4 x DBE108E

INFRASTRUCTURE REQUIREMENTS

- All devices must be in the same subnet
- 100Mb / s LAN network - 100BASE-TX
- Connection with UTP CAT5 / 6 cable
- Maximum length of each 100mt cable section
- Possibility to extend the Infrastructure by introducing optical fiber transceivers
- Switch required with a minimum forwarding rate of 6Gpps and a minimum switching capacity of 10Gbps

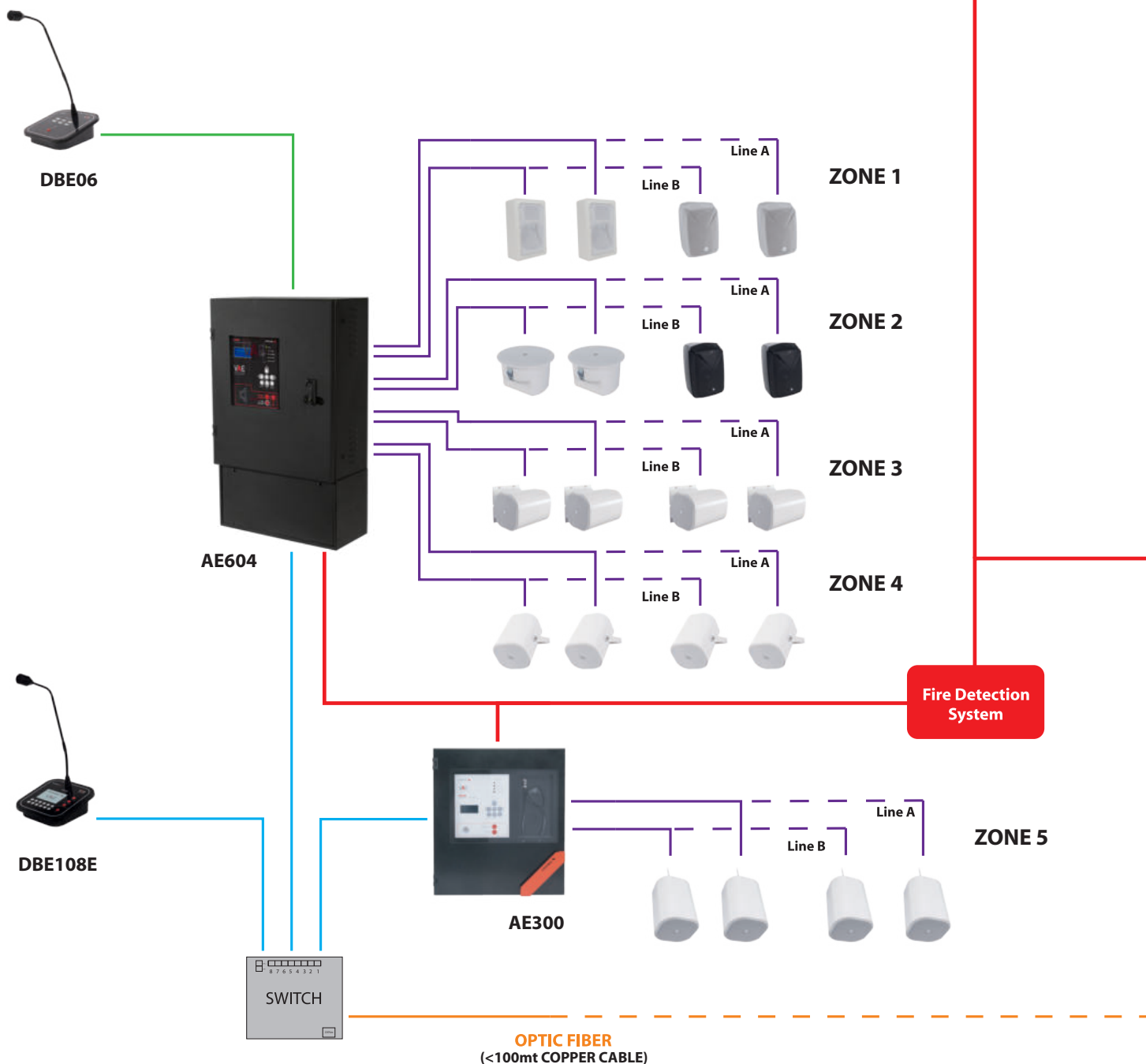

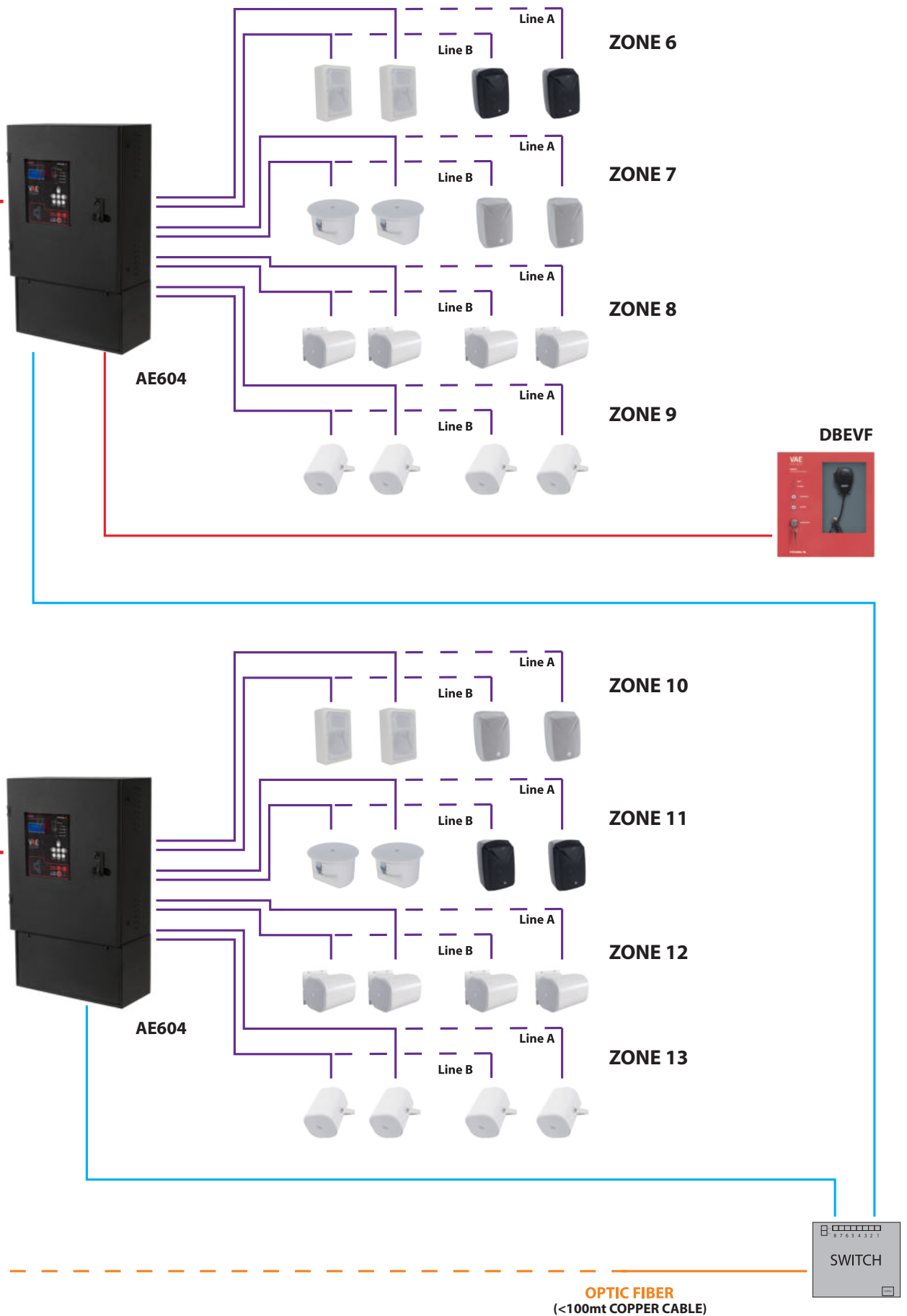

VAE COMPACT ALL-IN-ONE

TECHNICAL SPECIFICATIONS

Model	AE604
Main power source	AC mains 220V - 50/60Hz
Backup power source	48V – built-in batteries (4x 12V 18A/h sealed lead acid)
Backup power unit life	36h stand-by + 0.5h full power
Maximum power consumption	700W
Constant voltage	600W rms @ 1% THD on 100V loudspeaker line, all zones combined
Frequency response	100Hz – 18Khz @ -3dB
Signal to noise ratio	>90dB
Redundant power amplifier	Yes
Zones and loudspeaker lines	4 zones, redundant loudspeaker lines (A+B) on each zone
Loudspeaker line monitoring	20 Khz FFT impedance measurement +/-5% range. Detection of line cut, line short, line grounding. No end of line needed
User interface	Status leds + dot-matrix display, menu navigation keyboard, direct access status keys (alarm, warning, silencing)
Audio processing	DSP based, 16bit-48Khz; 3-band equalizer, Compressor/expander on microphone inputs; Pre-gain and master volume controls; Chime
Audio inputs/outputs	Background music; microphone input with phantom supply and enable contact input. Subwoofer line output
Front panel loudspeaker monitor	Yes
Emergency Firemen microphones	Frontpanel microphone with monitored capsule RJ14 input for WG-MTU01 desktop emergency call station
General input controls	8x dry contact inputs triggers for general announcement messages
General message scheduler	Yes
Input controls from fire alarm devices	2x monitored input contacts against cable-cut and cable short. Alarm, warning
Output status reporting	3x 1A 230V relay contacts (alarm, fault, disablement)
Communication	RS485, USB diagnostic port, Ethernet 10 BASE-T/100
Battery monitoring	Internal resistance DC measurement
Certifications and compliancy	EN54-16, EN54-4, BS-EN5839-8, 60849
Access restriction	Key-locked front door, password protected access to system menu
Chassis and dimensions	Main Unit: W:470mm - H: 550mm - D: 235mm Battery Case: W:470mm - H: 220mm - D: 200mm
Weight	Main Unit: 21.2 Kg Battery Case: 5.15 Kg

PRACTICAL EXAMPLE

SHOPPING CENTRE

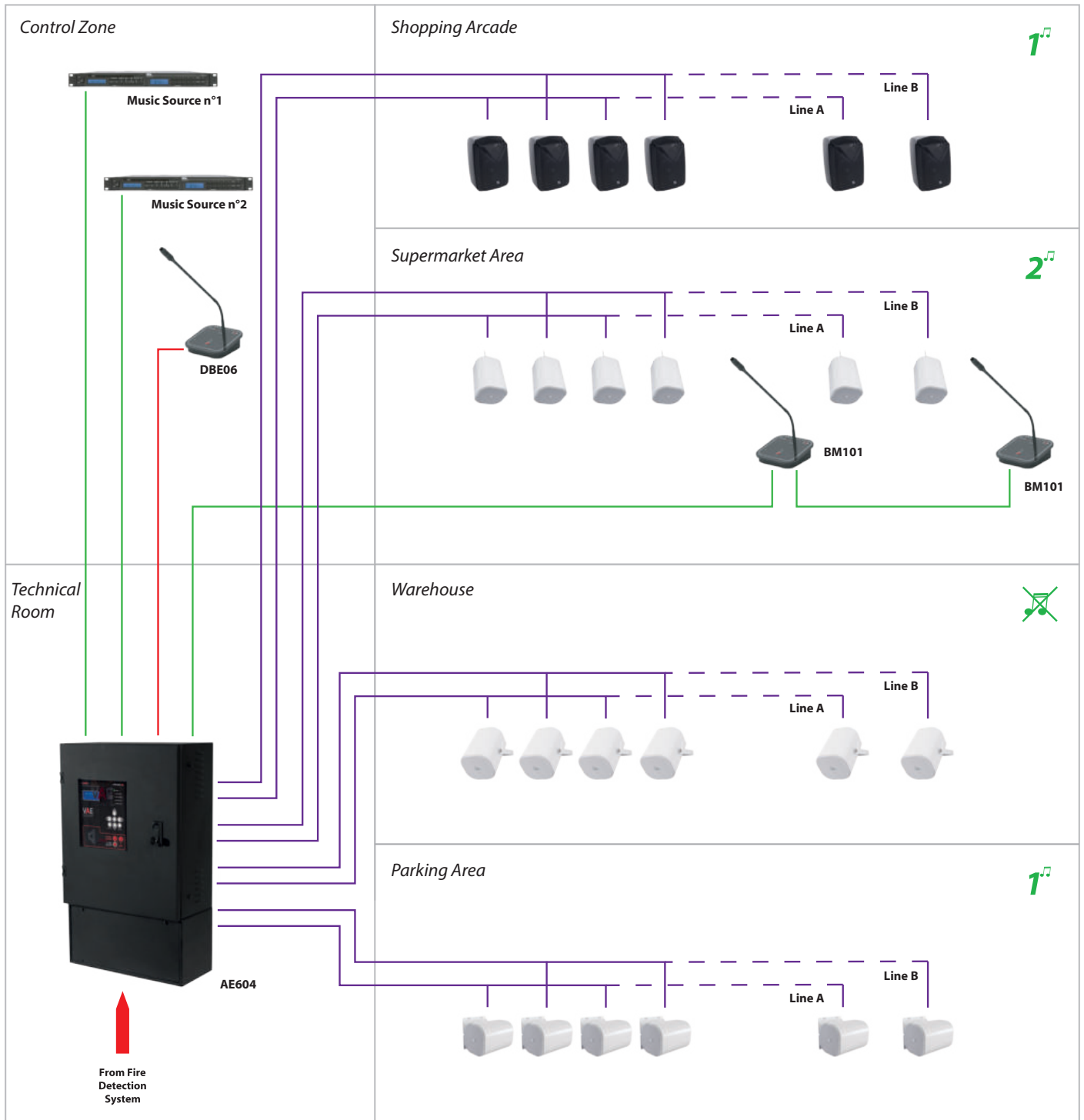

VAE COMPACT ALL-IN-ONE

PRATICAL EXAMPLE

HOTEL

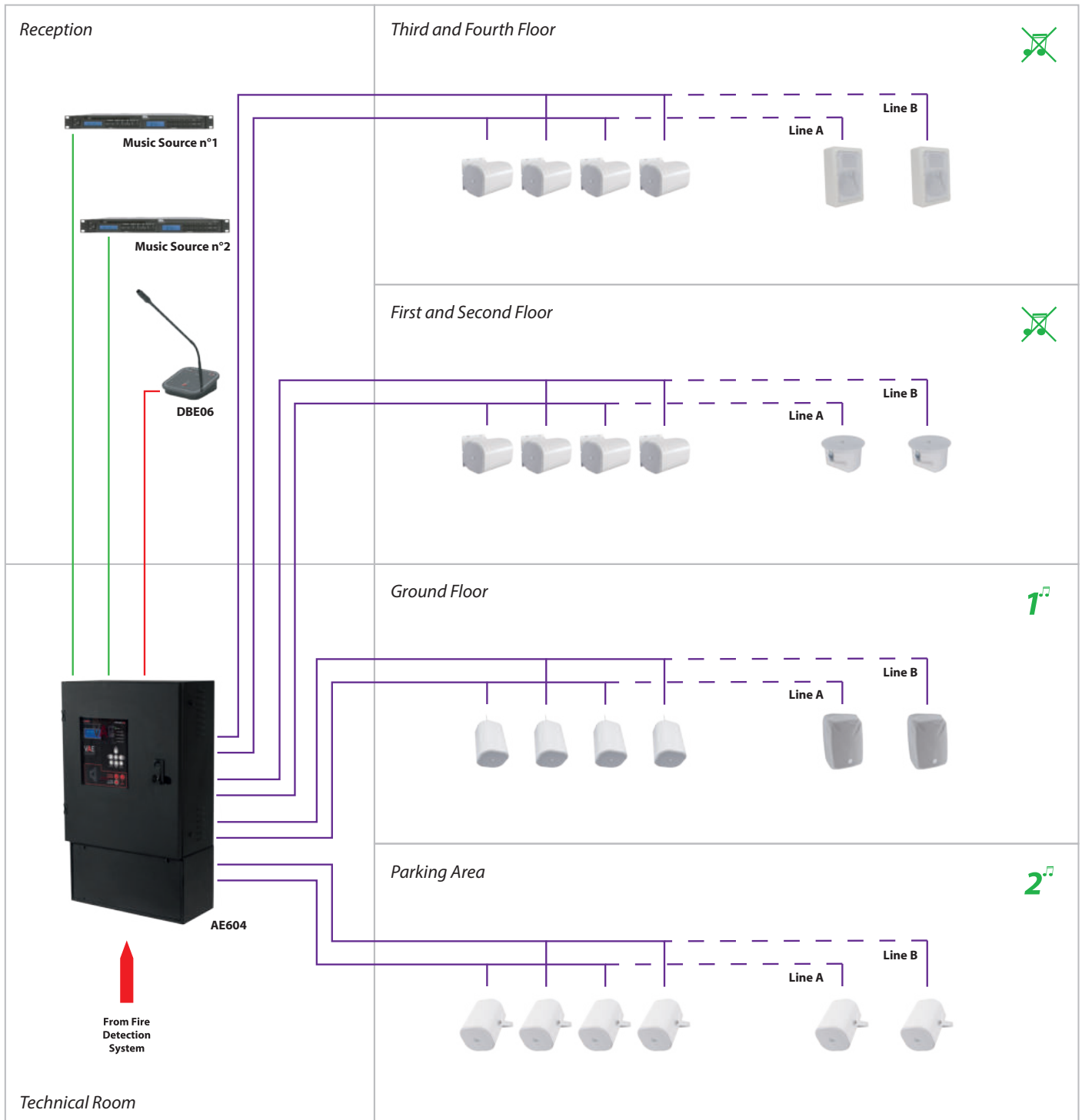

PRATICAL EXAMPLE

HOTEL WITH CONFERENCE ROOM

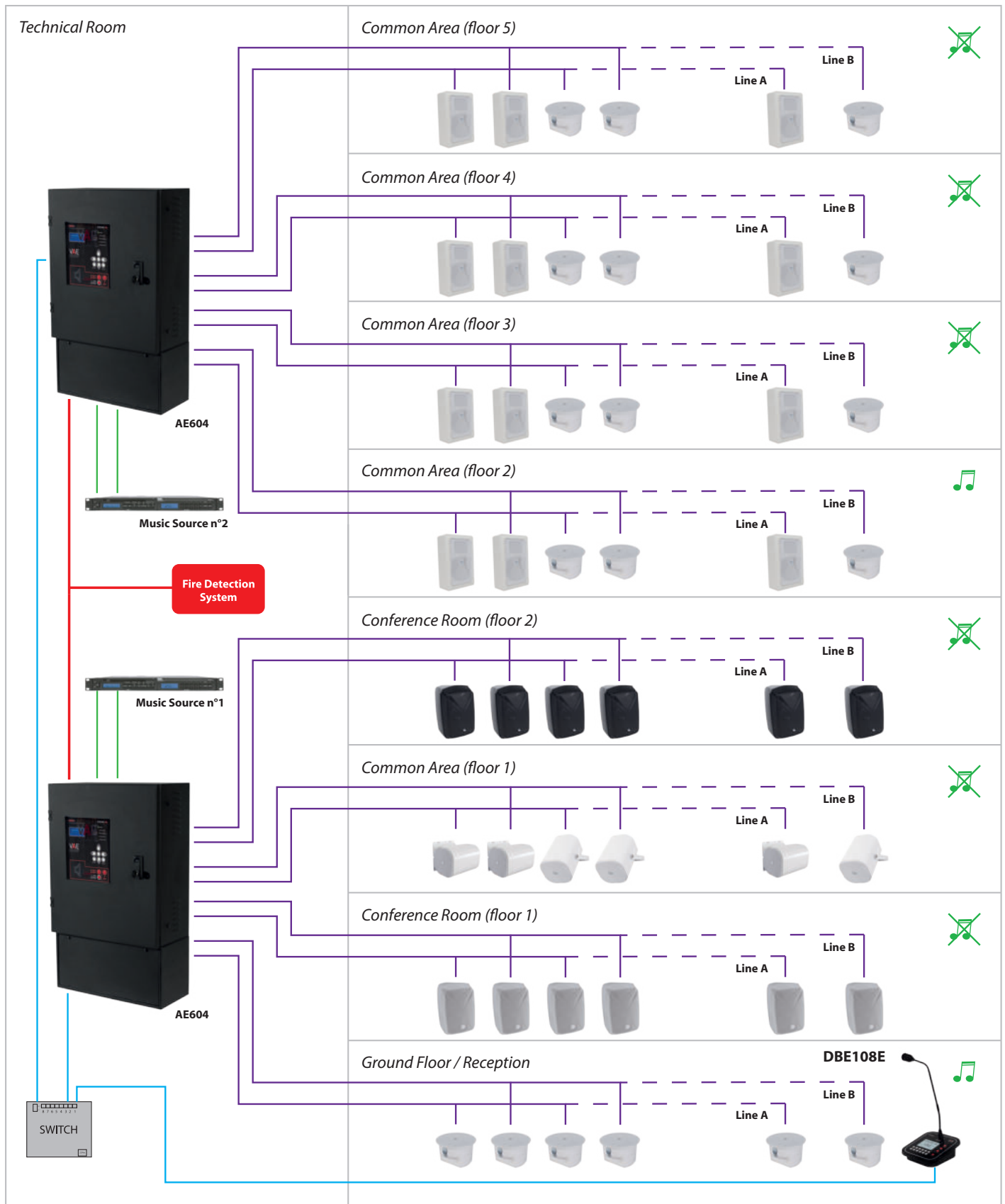

VAE COMPACT ALL-IN-ONE

AE300

The One and only pioneer

Wall mounted All-In-One voice alarm system compliant with EN54-16 standard, with testing and charge circuit compliant with EN54-4 standard. Class D main and spare amplifiers. 300W @ 100V on redundant loudspeaker lines (A + B). The system ensures full power performance even with backup power. DSP based audio management; balanced and isolated background music input, isolated microphone input with selectable 48Vdc phantom power supply and priority activation by contact; monitored input for remote emergency call stations; front panel fitted with monitor loudspeaker, monitored emergency PPT microphone, direct sending message keys, navigation keys, large display with LCD dot matrix. Line output for active sub-woofer; audio messages stored on uSD card: 8 general messages with activation from dedicated input contacts or incorporated scheduler, 2 monitored contacts for emergency announcement activation. 4 pcs. 12Vdc batteries 7.2Ah not included.

Certification EN54-16 EN54-4.



FEATURES

- Off the shelf integrated voice alarm system
- Out of the box installation ready
- High quality full digital audio DSP based architecture
- High output power: 300W
- Redundant loudspeaker lines (A+B)
- End of Line not required
- Embedded EN54-4 power supply and batteries
- 8 x general purpose triggerable messages
- 2 x voice alarm messages; monitored input triggers
- Background music input
- Ethernet
- Certification EN54-16 EN54-4



STAND ALONE APPLICATION

MAXIMUM EXTENSION CAPACITY

- 1 x AE300
- 8 x DBE01 or DBEVF

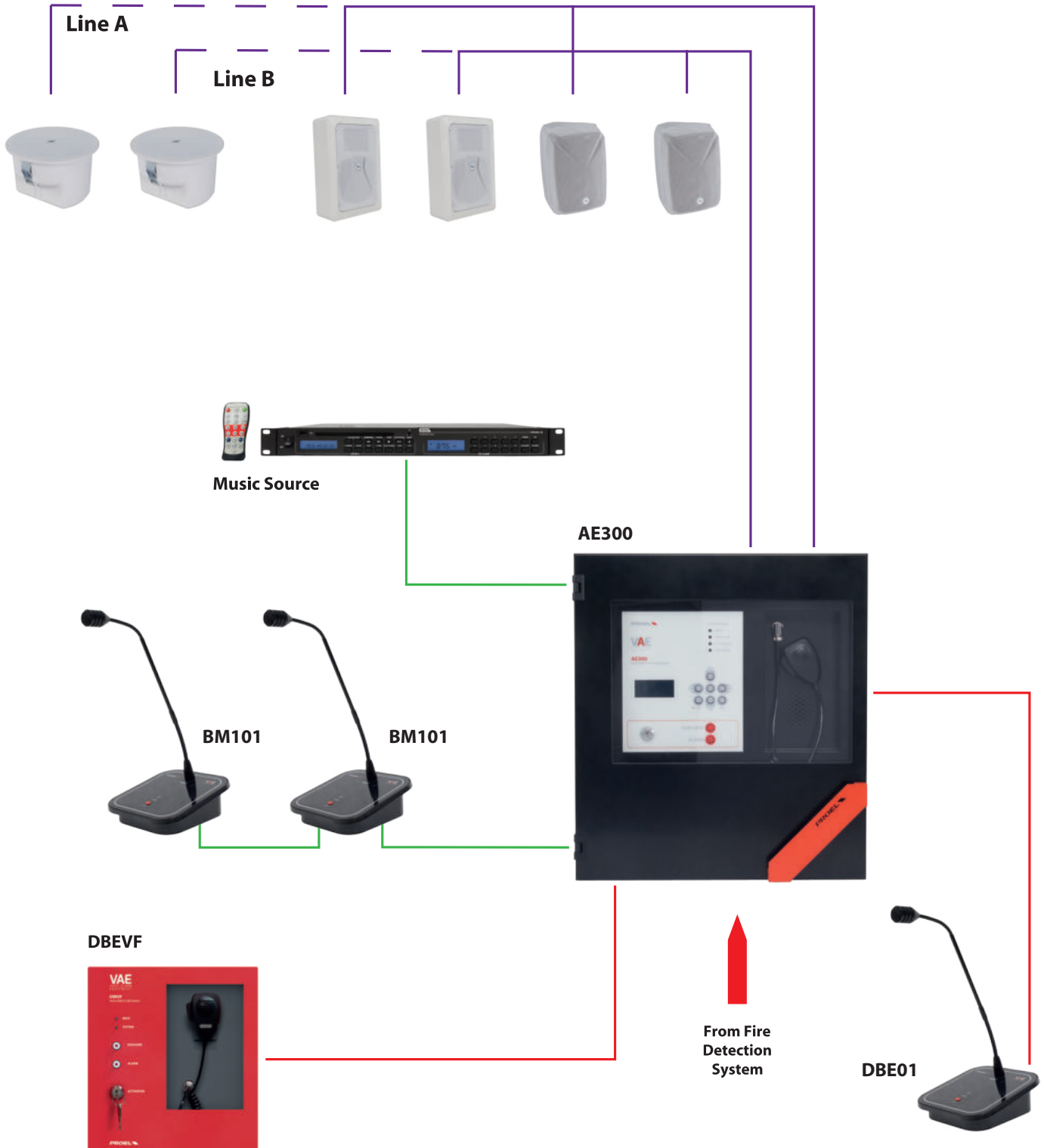

VAE COMPACT ALL-IN-ONE

NETWORK APPLICATION

MAXIMUM EXTENSION CAPACITY

- 8 x AE300/AE604
- 4 x DBE108E

INFRASTRUCTURE REQUIREMENTS

- All devices must be in the same subnet
- 100Mb / s LAN network - 100BASE-TX
- Connection with UTP CAT5 / 6 cable
- Maximum length of each 100mt cable section
- Possibility to extend the Infrastructure by introducing optical fiber transceivers
- Switch required with a minimum forwarding rate of 6Gpps and a minimum switching capacity of 10Gbps

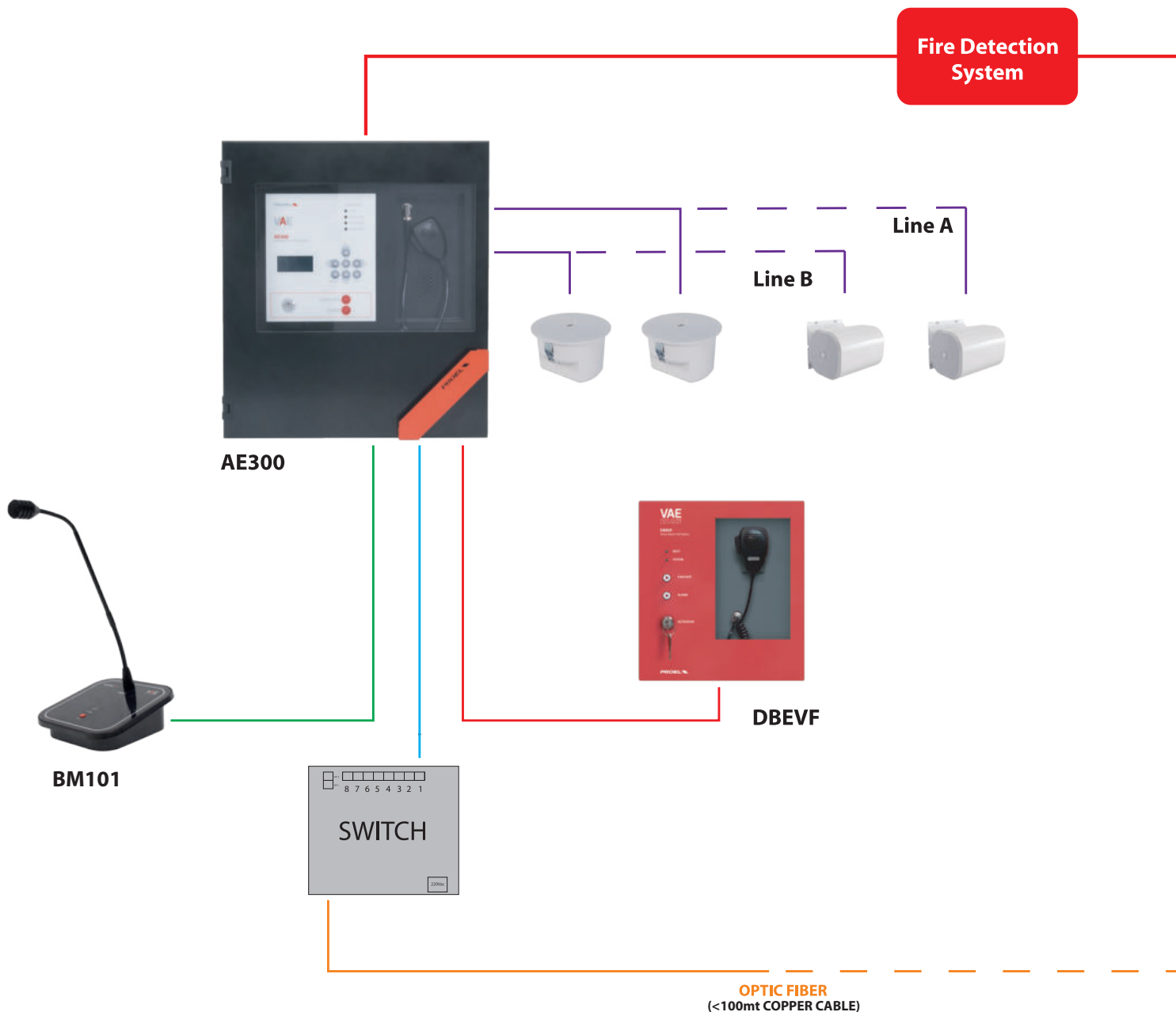

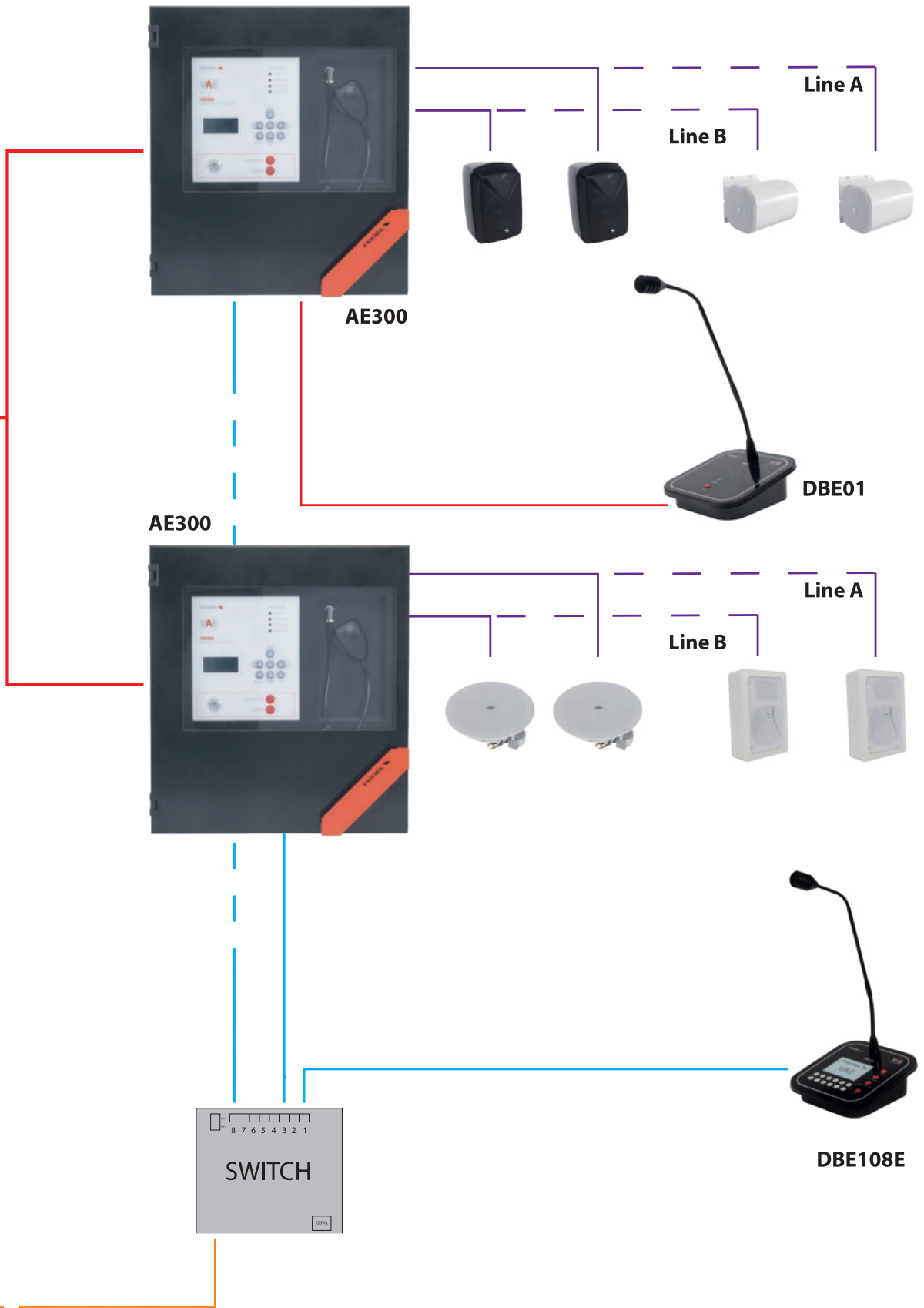

VAE COMPACT ALL-IN-ONE

TECHNICAL SPECIFICATIONS

Model	AE300
Main power source	AC mains 220V - 50/60Hz
Backup power source	48V – built-in batteries (4x 12V 7,2A/h sealed lead acid)
Backup power unit life	36h stand-by + 0.5h full power
Maximum power consumption	350W
Constant voltage	Single zone 300W rms @ 1% THD on 100V loudspeaker line
Frequency response	100Hz – 18Khz @ -3dB
Signal to noise ratio	>90dB
Redundant power amplifier	Yes
Redundant loudspeaker line	Yes (Line A, Line B)
Loudspeaker line monitoring	Line A and Line B independent 18 KhZ FFT impedance measurement +/-5% range. Detection of line cut, line short, line grounding. No end of line needed
User interface	Status leds + dot-matrix display, menu navigation keyboard, direct access status keys (alarm, warning, silencing)
Audio processing	DSP based, 16bit-48Khz; 3-band equalizer, Compressor/expander on microphone inputs; Pre-gain and master volume controls; Chime
Audio inputs/outputs	Background music; microphone input with phantom supply and enable contact input. Subwoofer line output
Front panel loudspeaker monitor	Yes
Emergency Firemen microphone	Frontpanel PPT microphone with monitored capsule RJ14 input for WG-MTU01 desktop emergency call station
General input controls	8x dry contact inputs triggers for general announcement messages
General message scheduler	Yes
Input controls from fire alarm devices	2x monitored input contacts against cable-cut and cable short. Alarm, warning
Output status reporting	2x 1A 230V relay contacts (alarm, fault)
Communication	RS485, RS232 diagnostic port, RJ45 10 BASE-T/100
Battery monitoring	Internal resistance DC measurement
Certifications and compliancy	EN54-16, EN54-4, BS-EN5839-8, 60849
Access restriction	Key-locked front door, password protected access to system menu
Chassiss, dimensions and weight	Steel, powder coated – 12Kg batteries included. Width 440mm, Height 11 Rack units (490mm) – Depth 150mm

PRACTICAL EXAMPLE

SUPERMARKET

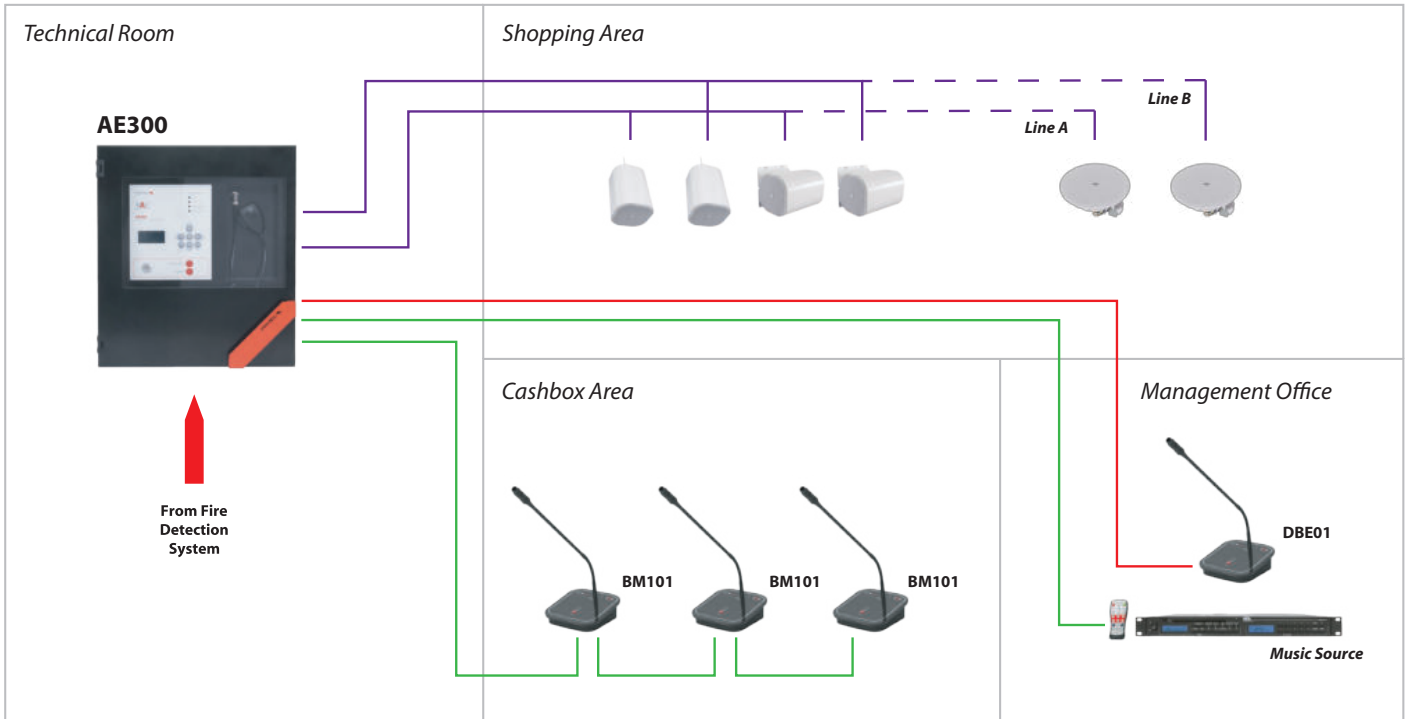

SCHOOL

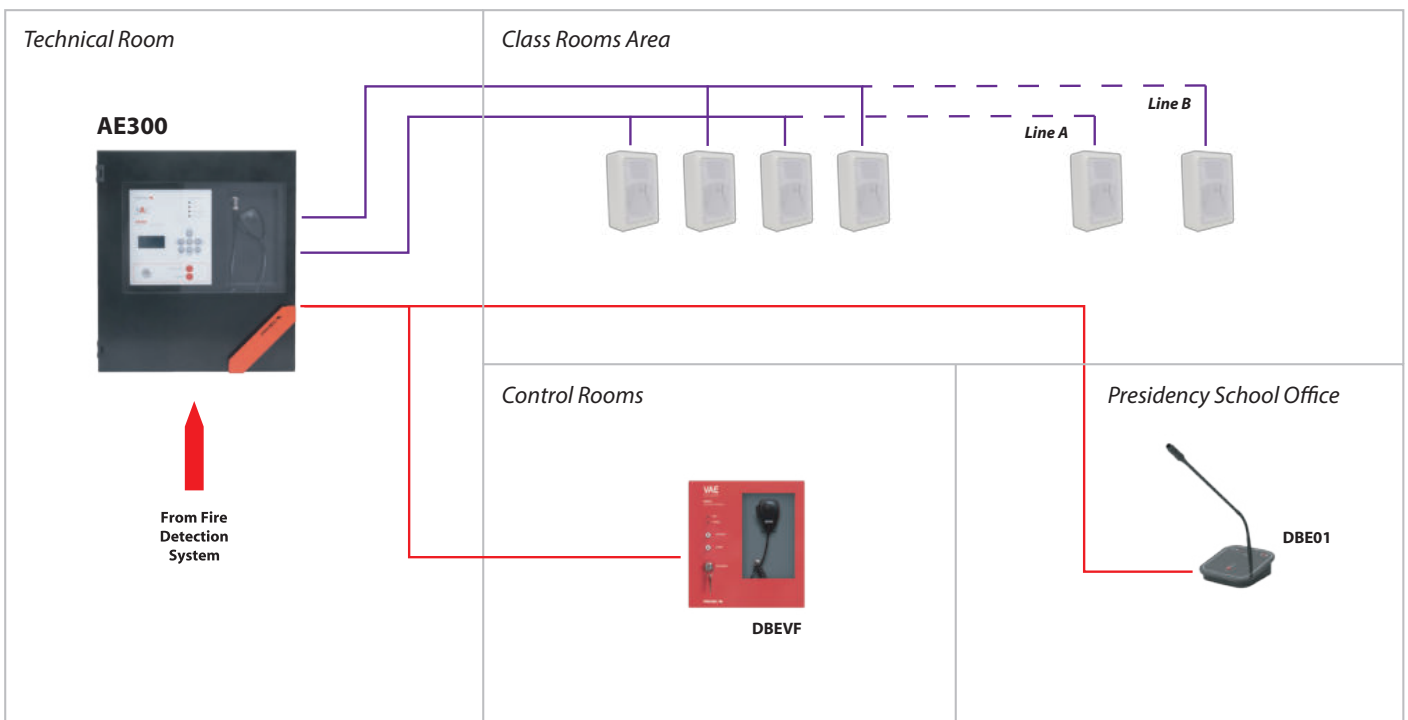





EMERGENCY AND ANNOUNCEMENT CALL STATIONS EN54-16 CERTIFIED

Sound systems, amplifiers and their accessories need to be practical, rugged and totally reliable. But once they are installed in their tech-rooms, what you deal with and always have under your eyes is the microphone call station. This is why we have combined functionality and performance with a touch of beauty.

All microphone stations are the ideal companions for both modular and all-in-one sound systems, allowing you to send just all over the building a general announcement, a live emergency call or to monitor and control the entire system.



EMERGENCY AND ANNOUNCEMENT CALL STATIONS

PA DBE01

Fully monitored desk call station according to EN54-16. Programmable "Talk" key, "Busy" and "System" LEDs, dynamic gooseneck microphone, automatic compressor, level adjustment trimmer. Wiring by Rj45 connector and CAT5 Cable. Power supply from RJ45 cable or 24Vdc local adaptor (not supplied).



TECHNICAL SPECIFICATIONS

Model	DBE01
Sensitivity	-55dB ± 3dB
Frequency Responce	70Hz ÷ 17KHz (-3dB)
Power Supply	from RJ45 cable or 24Vdc local adaptor (optional)
Gooseneck length	390 mm
Input/Output Connectors	2 x RJ45
Dimensions (W x H x D)	165 x 178 x 442 mm
Weight	1.1 Kg

PA DBE06

Fully monitored desk call station according to EN54-16. Software programmable capacitive selection keys, "Talk" and "Busy" Keys, "System" LEDs, dynamic gooseneck microphone, automatic compressor, level adjustment trimmer Wiring by Rj45 connector and CAT5 Cable. Wiring by Rj45 connector and CAT5 Cable. Power supply from RJ45 cable or 24Vdc local adaptor (not supplied).



TECHNICAL SPECIFICATIONS

Model	DBE06
Sensitivity	-55dB ± 3dB
Frequency Responce	70Hz ÷ 17KHz (-3dB)
Power Supply	from RJ45 cable or 24Vdc local adaptor (optional)
Gooseneck length	390 mm
Input/Output Connectors	2 x RJ45
Dimensions (W x H x D)	165 x 178 x 442 mm
Weight	1.1 Kg

PA DBE108

Fully monitored desk call station according to EN54-16.

10 keys dial keyboard, "Talk" and "Clear" key, 3 Evac activation keys, touch screen quarter VGA TFT display, dynamic gooseneck microphone, DSP audio processing. All keys and functions are software programmable. Wiring by Rj45 connector and CAT5 Cable.

Power supply from RJ45 cable or 24Vdc local adaptor (not supplied).



TECHNICAL SPECIFICATIONS

Model	DBE108
Sensitivity	-55dB ± 3dB
Frequency Responce	70Hz ÷ 17KHz (-3dB)
Power Supply	from RJ45 cable or 24Vdc local adaptor (optional)
Gooseneck length	390 mm
Input/Output Connectors	RJ45
Dimensions (W x H x D)	165 x 178 x 442 mm
Weight	1.2 Kg

PA DBE108E

Fully monitored Ethernet desk call station according to EN54-16. Connected to Proel's networkable emergency sound systems.

10 keys dial keyboard, "Talk" and "Clear" key, 3 Evac activation keys, touch screen quarter VGA TFT display, dynamic gooseneck microphone, DSP audio processing. All keys and functions are software programmable. Wiring by Rj45 connector and CAT5 Cable.

Power supply from 24Vdc local adaptor.



TECHNICAL SPECIFICATIONS

Model	DBE108E
Sensitivity	-55dB ± 3dB
Frequency Response	400Hz ÷ 8KHz (-3dB)
Dynamic range	72dB
Gooseneck type	Dynamic
Gooseneck length	390 mm
Input/Output Connectors	Ethernet 10/100
Power supply:	18-24Vdc
Dimensions (W x H x D)	165 x 178 x 442 mm
Weight	0.8 Kg

EMERGENCY AND ANNOUNCEMENT CALL STATIONS

PA DBEVF

Fully monitored, wall-mount, red metal box, EN54-16 Firemen's call station with handheld PTT Microphone. Fully software programmable, with status LEDs. Access to the security and fire alarm features system is granted by a key-lock. "EVAC" and "ALARM" Remote Message Activation Button.

Wiring by Rj45 connector and CAT5 Cable.

Power supply from RJ45 cable or 24Vdc local adaptor.



TECHNICAL SPECIFICATIONS

Model	DBEVF
Sensitivity	-40dB ± 3dB
Frequency Response	150Hz ÷ 14KHz (-3dB)
Power Supply	from RJ45 cable or 24Vdc local adaptor (optional)
Microphone	"PTT" Type
Input/Output Connectors	RJ45
Dimensions (W x H x D)	232 x 252 x 49 mm
Weight	2.6 Kg

PA BM101

Preamplified desk call station with chime generator and smart priority management.

The BM101 is a microprocessor based, pre-amplified, general announcement call station. For a better speech intelligibility, the unit has a compressor in the amplification path. The unit has also an embedded chime generator and smart priority management in case several stations are connected to the same bus. The audio output is balanced and the transformer coupled. The output level can be selected between MIC and LINE and the gain is regulated by a dedicated trimmer. Finally, its high output level makes the BM101 the best choice in setups with a very long cable length to the amplifier.

One or several BM101 stations are connected over a standard UTP Cat.5 (or higher) cable with RJ45 ending.

The PA BM101 is not a monitored emergency sound station. Still, it fits all Proel's and third party emergency sound systems, and its use is intended for general announcements only.



TECHNICAL SPECIFICATIONS

Model	BM101
Sensitivity	-55dB ± 3dB
Frequency Response	70Hz ÷ 17KHz (-3dB)
Power Supply	from RJ45 cable or 24Vdc local adaptor (optional)
Gooseneck length	390 mm
Input/Output Connectors	2 x RJ45
Dimensions (W x H x D)	165 x 178 x 442 mm
Weight	0.9 Kg

PA BM102

General announcement call station with dynamic microphone, Push to talk button and priority output contact (Normally Open). BM101 station is connected over a standard UTP Cat.5 (or higher) cable with RJ45 ending.

The PA BM102 is not a monitored emergency sound station. Still, it fits all Proel's and third party emergency sound systems, and its use is intended for general announcements only.



TECHNICAL SPECIFICATIONS

Model	BM102
Sensitivity	-55dB ± 3dB
Frequency Responce	70Hz ÷ 17KHz (-3dB)
Gooseneck length	390 mm
Input/Output Connectors	2 x RJ45
Dimensions (W x H x D)	165 x 178 x 442 mm
Weight	0.8 Kg

CROSSING

Model	PA DBE01	PA DBE06	PA DBE108E	PA DBE108	PA DBEVF	PA BM101	PA BM102
PA AE604	x	x	x		x	x *not for EVAC use	x *not for EVAC use
PA AE300	x		x		x	x *not for EVAC use	x *not for EVAC use
PA AEM5Z	x	x		x	x	x *not for EVAC use *not dedicate input	x *not for EVAC use *not dedicate input

ARTIA SERIES EN54-24 CERTIFIED SPEAKER

This premium loudspeaker systems, designed and engineered in Italy, come from Proel's 30-years experience in the development of sound reinforcement systems. Not only they outperform the strictest quality and performance criteria, but they fulfil EN54-24 standard for the use in fire alarm systems.

The new ARTIA series will enhance every sound system and will be at its ease in any kind of application, no matter if background music, voice announcements or emergency calls.





ARTIA SERIES

PA A51T

A51T is a compact, two-way, surface-mount loudspeaker system designed for constant-voltage or constant-impedance applications. It is equipped with a 76 mm (3") woofer and a 1" dome tweeter, able to provide an excellent speech intelligibility with wide dispersion, together with a very good background music reproduction.

A51T features a transformer to operate on 100V and 70V constant voltage systems. In a sealed compartment on the rear panel, together with the rotary selector for power taps or impedance, it includes, in compliance with EN 54-24:2008 standard, a ceramic terminal block and a thermal fuse; it is, therefore, suitable for the use in voice alarm systems.

The ABS cabinet complies to UL 94V0 and is available in black (**A51TB**) or white (**A51TW**) color finishing, allowing the best décor matching in any environment.

The IP55C environment protection allows the A51T speaker to be installed both indoors and outdoors.



TECHNICAL SPECIFICATIONS

Model	A51TB - A51TW
System type	Wall Mount Speaker
Drivers	1" tweeter, 5" woofer
Power Rating @ 8Ω (nominal)	50 W
Rated Noise Power 100h	50 W
Power Rating @ 100V	50 / 25 / 12.5 / 6.25 W
Power Rating @ 70V	50 / 25 / 12.5 / 6.25 / 3.12 W
Impedance	8 Ω (nominal) 200 / 400 / 800 / 1.6K Ω @ 100V 100 / 200 / 400 / 800 / 1.6K Ω @ 70V
Connector	Ceramic Terminal Block
Power Selection	Rotary Switch
Frequency Response (-10 dB)	90 - 20k Hz
Sensitivity at 1W (1 kHz, 1m / 4m)	89 / 77 dB
Max SPL (1 kHz, 1m / 4m)	106 / 94 dB
Coverage Angle at 500 / 1k / 2k / 4k Hz(-6dB)	180° / 180° / 180° / 120°
Cabinet	Black (RAL 9011)/White (RAL 9016)
Material	ABS / Aluminium
Environmental Type	B (IP55C)
Operating Temperature	-25 ÷ +70 °C (-13 ÷ +158 °F)
Relative Humidity	< 95%
Dimensions (mm)	170 x 245 x 175 (W x H x D)
Mounting	On wall using supplied bracket
Weight (Kg)	2.3
Standard Compliance	EN54-24:2008

PA A31T

A31T is a compact, two-way, surface-mount loudspeaker system designed for constant-voltage or constant-impedance applications. It is equipped with a 76 mm (3") woofer and a 1" dome tweeter, able to provide an excellent speech intelligibility with wide dispersion, together with a very good background music reproduction.

A31T features a transformer to operate on 100V and 70V constant voltage systems. In a sealed compartment on the rear panel, together with the rotary selector for power taps or impedance, it includes, in compliance with EN 54-24:2008 standard, a ceramic terminal block and a thermal fuse and it is, therefore, suitable for the use in voice alarm systems.

The ABS cabinet complies to UL 94V0 and is available in black (**A31TB**) or white (**A31TW**) color finishing, allowing the best décor matching in any environment.

The IP55C environment protection allows the A31T speaker to be installed both indoors and outdoors.



TECHNICAL SPECIFICATIONS

Model	A31TB - A31TW
System type	Wall Mount Speaker
Drivers	1" tweeter, 3" woofer
Power Rating @ 8Ω (nominal)	25W
Rated Noise Power 100h	25 W
Power Rating @ 100V	25 / 12.5 / 6.25 / 3.12 W
Power Rating @ 70V	25 / 12.5 / 6.25 / 3.12 / 1.56 W
Impedance	8 Ω (nominal) 400 / 800 / 1.6K / 3.2K Ω @ 100V 200 / 400 / 800 / 1.6K / 3.2K Ω @ 70V
Connector	Ceramic Terminal Block
Power Selection	Rotary Switch
Frequency Response (-10 dB)	120 - 20k Hz
Sensitivity at 1W (1 kHz, 1m / 4m)	87 / 75 dB
Max SPL (1 kHz, 1m / 4m)	101 / 89 dB
Coverage Angle at 500 / 1k / 2k / 4k Hz(-6dB)	180° / 120° / 120° / 90°
Cabinet	Black (RAL 9011)/White (RAL 9016)
Material	ABS / Aluminium
Environmental Type	B (IP55C)
Operating Temperature	-25 ÷ +70 °C (-13 ÷ +158 °F)
Relative Humidity	< 95%
Dimensions (mm)	140 x 209 x 125 (W x H x D)
Mounting	On wall using supplied bracket
Weight (Kg)	1.74
Standard Compliance	EN54-24:2008



ARTIA SERIES

PA AP50T

AP50T is an elegant indoor/outdoor sound projector featuring an epoxy coated high-grade aluminum extrusion enclosure. It is equipped with a 127 mm (5") full-range driver, able to provide an excellent speech intelligibility with wide dispersion, together with a good background music reproduction.

AP50T includes a transformer to operate on 100V and 70V constant voltage systems with three different power taps. In compliance with EN 54-24:2008 standard, it includes a ceramic terminal block and a thermal fuse and it is, therefore, suitable for the use in voice alarm systems. Thanks to its rugged construction and IP55 protection, this unit is suited for both indoor and outdoor application in shopping centres, exhibition centres, railway, bus stations, etc.



TECHNICAL SPECIFICATIONS

Model	AP50T
System type	Sound Projector
Drivers	5" dual cone full range
Rated Noise Power 100h	20 W
Power Rating @ 100V	20 / 10 / 5 W
Power Rating @ 70V	10 / 5 / 2.5 W
Impedance	500 / 1K / 2K Ω @ 100V 500 / 1K / 2K Ω @ 70V
Connector	Ceramic Terminal Block
Power Selection	On terminal block
Frequency Response (-10 dB)	100 - 12k Hz
Sensitivity at 1W (1 kHz, 1m / 4m)	90 / 78 dB
Max SPL (1 kHz, 1m / 4m)	103 / 91 dB
Coverage Angle at 500 / 1k / 2k / 4k Hz(-6dB)	180° / 120° / 80° / 60°
Cabinet	White (RAL 9016)
Material	Aluminium
Environmental Type	B (IP55C)
Operating Temperature	-25 ÷ +70 °C (-13 ÷ +158 °F)
Relative Humidity	< 95%
Dimensions (mm)	140 x 140 x 195 (W x H x D)
Mounting	Brick/concrete on ceilings/wall
Weight (Kg)	2.63
Standard Compliance	EN54-24:2008

PA AP52T

AP52T is an elegant indoor/outdoor bi-directional sound projector featuring an epoxy coated high-grade aluminum extrusion enclosure. It is equipped with two 127 mm (5") full-range drivers, able to provide an excellent speech intelligibility with wide dispersion, together with a good background music reproduction.

AP52T includes a transformer to operate on 100V and 70V constant voltage systems with three different power taps. In compliance with EN 54-24:2008 standard, it includes a ceramic terminal block and a thermal fuse and it is, therefore, suitable for the use in voice alarm systems. Thanks to its rugged construction and IP55 protection, this unit is suited for both indoor and outdoor application in shopping centres, exhibition centres, railway, bus stations, etc.



TECHNICAL SPECIFICATIONS

Model	AP52T
System type	Bi-Directional Sound Projector
Drivers	2x 5" full range
Rated Noise Power 100h	20 W
Power Rating @ 100V	20 / 10 / 5 W
Power Rating @ 70V	10 / 5 / 2.5 W
Impedance	500 / 1K / 2K Ω @ 100V 500 / 1K / 2K Ω @ 70V
Connector	Ceramic Terminal Block
Power Selection	On terminal block
Frequency Response (-10 dB)	120 - 12k Hz
Sensitivity at 1W (1 kHz, 1m / 4m)	88 / 76 dB
Max SPL (1 kHz, 1m / 4m)	101 / 89 dB
Coverage Angle at 500 / 1k / 2k / 4k Hz(-6dB)	(2x) 180° / 120° / 80° / 60°
Cabinet	White (RAL 9016)
Material	Aluminium
Environmental Type	B (IP55C)
Operating Temperature	-25 ÷ +70 °C (-13 ÷ +158 °F)
Relative Humidity	< 95%
Dimensions (mm)	140 x 185 x 200 (W x H x D)
Mounting	Brick/concrete on ceilings/wall
Weight (kg)	3.45
Standard Compliance	EN54-24:2008

PA AH50T

AH50T is an elegant indoor/outdoor hanging speaker featuring an epoxy coated high-grade aluminum extrusion enclosure. It is equipped with a 127 mm (5") full-range driver, able to provide an excellent speech intelligibility with wide dispersion, together with a good background music reproduction.

AH50T includes a transformer to operate on 100V and 70V constant voltage systems with three different power taps. In compliance with EN 54-24:2008 standard, it includes a ceramic terminal block and a thermal fuse and it is, therefore, suitable for the use in voice alarm systems. Thanks to its rugged construction and IP55 protection, this unit is suited for both indoor and outdoor application in shopping centres, exhibition centres, railway, bus stations, etc.



TECHNICAL SPECIFICATIONS

Model	AH50T
System type	Hanging Speaker
Drivers	5" dual cone full range
Rated Noise Power 100h	20 W
Power Rating @ 100V	20 / 10 / 5 W
Power Rating @ 70V	10 / 5 / 2.5 W
Impedance	500 / 1K / 2K Ω @ 100V 500 / 1K / 2K Ω @ 70V
Connector	Ceramic Terminal Block
Power Selection	On terminal block
Frequency Response (-10 dB)	100 - 12k Hz
Sensitivity at 1W (1 kHz, 1m / 4m)	90 / 78 dB
Max SPL (1 kHz, 1m / 4m)	103 / 91 dB
Coverage Angle at 500 / 1k / 2k / 4k Hz(-6dB)	180° / 120° / 80° / 60°
Cabinet	White (RAL 9016)
Material	Aluminium
Environmental Type	B (IP55C)
Operating Temperature	-25 ÷ +70 °C (-13 ÷ +158 °F)
Relative Humidity	< 95%
Dimensions (mm)	140 x 140 x 195 (W x H x D)
Mounting	Suspended from ceilings
Weight (kg)	2.77
Standard Compliance	EN54-24:2008

PA AIW50T

AIW50T is an elegant indoor wall speaker featuring an ABS injected frame and an epoxy coated aluminium grid. It is equipped with a 127 mm (5") woofer and a 1" dome tweeter, providing a wide frequency response with a natural, smooth sound reproduction, ideal for the use in PA systems and in background music applications.

AIW50T includes a transformer to operate on constant voltage 100V and 70V systems with three different power taps. In compliance with EN 54-24:2008 standard, it incorporates a ceramic terminal block and a thermal fuse and is, therefore, suitable for the use in voice alarm systems. AIW50T can be installed flush with the wall on plasterboards or wooden panels. Using the optional accessory AIW50FRAME the speaker can be mounted on the surface of concrete or brick walls.

The elegant design provides a cosmetically clean appearance, which makes this unit is suited for indoor application in shopping centres, exhibition centres, railway, bus stations, etc.

PA AIW50FRAME

This optional accessory allows to install the AIW50T on the surface of concrete or brick walls.



PA AIW50T



PA AIW50FRAME

TECHNICAL SPECIFICATIONS

Model	AIW50T
System type	In-Wall Speaker
Drivers	1" tweeter - 5" woofer
Rated Noise Power 100h	12 W
Power Rating @ 100V	12 / 6 / 3 W
Power Rating @ 70V	6 / 3 / 1.5 W
Impedance	850 / 1.7K / 3.4K Ω @ 100V 850 / 1.7K / 3.4K Ω @ 70V
Connector	Ceramic Terminal Block
Power Selection	On terminal block
Frequency Response (-10 dB)	120 - 20k Hz (on wall)
Sensitivity at 1W (1 kHz, 1m / 4m)	89 / 77 dB
Max SPL (1 kHz, 1m / 4m)	100 / 88 dB
Coverage Angle at 500 / 1k / 2k / 4k Hz(-6dB)	130° / 130° / 120° / 90°
Cabinet	White (RAL 9016)
Material	ABS / Aluminium
Environmental Type	A (IP32C)
Operating Temperature	-10 ÷ +55 °C (+14 ÷ +131 °F)
Relative Humidity	< 95%
Dimensions (mm)	280 x 192 x 77 (W x H x D)
Mounting	In-wall or on surface with AIW50FRAME
Weight (kg)	1.62
Standard Compliance	EN54-24:2008

PA AC61T

AC61T is a premium ceiling speaker featuring an ABS injected frame and an epoxy coated aluminum grid. It is equipped with a 154 mm (6") woofer and a 1" dome tweeter, able to provide an excellent speech intelligibility with wide dispersion, together with a very good background music reproduction.

AC61T includes a transformer to operate on 100V and 70V constant voltage systems with three different power taps. The frame is fitted with a fire-resistant ABS rear cover that seals the loudspeakers' compartment. In compliance with EN 54-24:2008 standard, the AC61T includes a ceramic terminal block and a thermal fuse and it is, therefore, suitable for the use in voice alarm systems.

A simple spring system significantly reduces the installation time, while the elegant design provides a cosmetically clean appearance, which makes this unit suited for indoor application in shopping centres, exhibition centres, railway, bus stations, etc.



TECHNICAL SPECIFICATIONS

Model	AC61T
System type	Ceiling Speaker
Drivers	1" tweeter - 6" woofer
Rated Noise Power 100h	12 W
Power Rating @ 100V	12 / 6 / 3 W
Power Rating @ 70V	6 / 3 / 1.5 W
Impedance	850 / 1.7K / 3.4K Ω @ 100V 850 / 1.7K / 3.4K Ω @ 70V
Connector	Ceramic Terminal Block
Power Selection	On terminal block
Frequency Response (-10 dB)	200 - 20k Hz (on wall)
Sensitivity at 1W (1 kHz, 1m / 4m)	95 / 83 dB
Max SPL (1 kHz, 1m / 4m)	105 / 93 dB
Coverage Angle at 500 / 1k / 2k / 4k Hz(-6dB)	120° / 120° / 90° / 60°
Cabinet	White (RAL 9016)
Material	ABS / Aluminium
Environmental Type	A (IP44C)
Operating Temperature	-10 ÷ +55 °C (+14 ÷ +131 °F)
Relative Humidity	< 95%
Dimensions (mm)	186 x 114 (ø x D)
Mounting	ø 166mm cut out
Weight (kg)	1.07
Standard Compliance	EN54-24:2008

PA AC60T

AC60T is a ceiling speaker featuring an ABS injected frame and an epoxy coated aluminum grid. It is equipped with a 154 mm (6") dual-cone full-range speaker, able to provide an excellent speech intelligibility with wide dispersion, together with a good background music reproduction.

AC60T includes a transformer to operate on 100V and 70V constant voltage systems with three different power taps. In compliance with EN 54-24:2008 standard, it includes a ceramic terminal block and a thermal fuse and it is, therefore, suitable for the use in voice alarm systems.

A simple spring system significantly reduces the installation time, while the elegant design provides a cosmetically clean appearance, which makes this unit is suited for indoor application in shopping centres, exhibition centres, railway, bus stations, etc.



Cover Included

TECHNICAL SPECIFICATIONS

Model	AC60T
System type	Ceiling Speaker
Drivers	6" dual cone full range
Rated Noise Power 100h	12 W
Power Rating @ 100V	12 / 6 / 3 W
Power Rating @ 70V	6 / 3 / 1.5 W
Impedance	850 / 1.7K / 3.4K Ω @ 100V 850 / 1.7K / 3.4K Ω @ 70V
Connector	Ceramic Terminal Block
Power Selection	On terminal block
Frequency Response (-10 dB)	120 - 20k Hz (on wall)
Sensitivity at 1W (1 kHz, 1m / 4m)	94 / 82 dB
Max SPL (1 kHz, 1m / 4m)	104 / 92 dB
Coverage Angle at 500 / 1k / 2k / 4k Hz(-6dB)	120° / 120° / 90° / 45°
Cabinet	White (RAL 9016)
Material	ABS / Aluminium
Environmental Type	A (IP32C)
Operating Temperature	-10 ÷ +55 °C (+14 ÷ +131 °F)
Relative Humidity	< 95%
Dimensions (mm)	186 x 74 (ø x D)
Mounting	ø 166mm cut out
Weight (kg)	0.81
Standard Compliance	EN54-24:2008



PROEL

ITALY

Proel Lab Spa
Acquaviva Picena

UK

Proel International Ltd.
London

KOREA

Proel Korea Co. Ltd.
Gyunggi-Do

MALAYSIA

Proel Malaysia Snd. Bhd.
Petaling Jaya

USA

Proel North America Inc.
Los Angeles

TUNISIE

Proel Tunisia Sarl
Tunisi

PROEL SPA

(Worldwide Headquarters)
Via alla Ruenia, 37/43
64027 Sant'Omero (TE) - ITALY
Tel. +39 0861 81241
Fax +39 0861 887862
P.I. 00778590679
N.Reg.AEE IT 08020000002762

info@proel.com
www.proel.com

